

CORE UNIT SECTION

SHORT ENGINE	
ACEK6370	
CYLINDER BLOCK	
ACHK0018	
CRANKSHAFT, PISTONS AND CONNECTING RODS	
ACHK0018	
CYLINDER HEAD	
ACHK0018	
ROCKER SHAFT	
ACHK0018	
TIMING GEAR AND CAMSHAFT	
ACHK0018	
LUBRICATING OIL PUMP AND DELIVERY HOUSING	
ACHK0018	

PAGE

1
2
4
6
8
9
13**OPTIONS SECTION**

FUEL INJECTION EQUIPMENT (DIESEL)	
AFHK2081	
FLYWHEEL HOUSING	
CDHK0754	
FLYWHEEL AND STARTER RING	
DDHK0818	
STARTER MOTOR	
EDHK0611	
LUBRICATING OIL SUMP	
GBHK1379	
LUBRICATING OIL FILLER AND BREATHER	
HBHK1389	
LUBRICATING OIL FILTER AND INTEGRAL OIL COOLER	
JBHK1071	
FRONT END DRIVE INPUT	
KBHK0577	
WATER PUMP, THERMOSTAT AND HEAT EXCHANGER	
LBHK1435	
FAN AND EXTENSION	
MDHK0817	
ALTERNATOR AND GENERATOR	
NDHK1760	
GEAR DRIVE AUXILIARY DRIVE OPTIONS	
QDHK0903 ● QDHK0856	
INDUCTION MANIFOLD	
TBHK0555	
EXHAUST MANIFOLD	
UBHK0347	
LOW PRESSURE FUEL SYSTEM	
VBHK1393	
COLD START SYSTEM	
WDHK0195	
ENGINE LIFTING	
XBHK0308	

PAGE

14
18
19
20
23
24
25
26
27
28
29
31
32
33
34
36
37**ACCESSORIES SECTION**

THROTTLE AND STOP CONTROLS	
ZAHK0519	
LUB. OIL PRESSURE SWITCH AND GAUGE	
ZJHK0404	
TEMPERATURE GAUGE AND SENDER	
ZLHK0180	
RADIATOR AND COWLING	
ZMHK0249	
TACHOMETER AND HOUR RECORDER	
ZOHK0529	
APPLICATION MISCELLANEOUS AND AUXILIARIES	
ZZHK0386	
JOINTS AND GASKETS - COMPLETE SERVICE KIT	
SGBK0012	

PAGE

31
31
41
41
41
41
41
41
41
41
41
41

SECTION DES EQUIPEMENT DE BASE

	PAGE
MOTEUR EMBIELLE	
ACEK6370	1
BLOC-CYLINDRES	
ACHK0018	2
VILEBREQUIN PISTONS ET BIELLES	
ACHK0018	4
CULASSE	
ACHK0018	6
AXE DES CULBUTEURS	
ACHK0018	8
DISTRIBUTION ET ARBRE A CAMES	
ACHK0018	9
POMPE A HUILE ET CLAPET DE DECHARGE	
ACHK0018	13

SECTION DES EQUIPEMENTS OPTIONNELS

	PAGE
EQUIPEMENT D'INJECTION (DIESEL)	
AFHK2081	14
CARTER VOLANT	
CDHK0754	18
VOLANT ET COURONNE DEMARRAGE	
DDHK0818	19
DEMARREUR	
EDHK0611	20
CARTER D'HUILE	
GBHK1379	23
REMPLISSEUR D'HUILE ET RENIFLARD	
HBHK1389	24
FILTRE A HUILE ET REFROIDISSEUR D'HUILE	
JBHK1071	25
PUISSANCE ABSORBEE A L'AVANT	
KBHK0577	26
POMPE A EAU ET THERMOSTAT	
LBHK1435	27
VENTILATEUR ET ENTRETOISE	
MDHK0817	28
ALTERNATEUR ET DYNAMO	
NDHK1760	29
ENTRAINEMENT PAR PIGNON DES EQUIPEMENTS AUXILIAIRES	
QDHK0903 ● QDHK0856	31
COLLECTEUR D'ADMISSION	
TBHK0555	32
COLLECTEUR ECHAPPEMENT	
UBHK0347	33
CIRCUIT CARBURANT BASSE PRESSION	
VBHK1393	34
DIPOSITIF DEPART A FROID	
WDHK0195	36
LEVAGE MOTEUR	
XBHK0308	37

SECTION DES EQUIPEMENTS ACCESSOIRES

CONTROLE ACCELERATION ET STOP	
ZAHK0519	
MANO. CONTACT PRESSION D'HUILE ET MANOMETRE	
ZJHK0404	
MANOMETRE TEMPERATURE TRANSMETTEUR	
ZLHK0180	
RADIATEUR ET CAPOTAGE	
ZMHK0249	
COMPTE-TOURS ET COMPTEUR D'HEURES	
ZQHK0529	
APPLICTIONS DIVERSES ET AUXILIAIRES	
ZZHK0386	
JEU DE JOINTS COMPLET	
SGBK0012	

GRUNDMOTOR

RUMPF MOTOR
ACEK6370
ZYLINDERBLOCK
ACHK0018
KURBELWELLE,KOLBEN UND PLEUEL
ACHK0018
ZYLINDERKOPF
ACHK0018
KIPPHEBELANLAGE
ACHK0018
STEUERGETRIEBE UND NOCKENWELLE
ACHK0018
SCHMIEROLPUMPE UND ENTLASTUNGSVENTIL
ACHK0018

PAGE

1
2
4
6
8
9
13

ANBAUTEILE WAHIWEISE

EINSPRITZANLAGE (DIESEL)
AFHK2081
SCHWUNGRADGEHAUSE
CDHK0754
SCHWUNGRAD UND ZAHNKRANZ
DDHK0818
ANLASSER
EDHK0611
SCHMIERDELWANNE
GBHK1379
DELEINFUELLSTUTZEN UND ENTLUEFTUNG
HBHK1389
SCHMIEROLFILTER UND MOTORSEITIGER DELHUEHLER
JBHK1071
KURBELWELLENGETRIEBE (VORNE)
KBHK0577
WASSERPUMPE,THERMOSTAT UND WAERMETAUSCHER
LBHK1435
LUFTER UND ZWISCHENSTUECK
MDHK0817
DREHSTROM-WECHSELSTROM-LICHTMASCHINE
NDHK1760
ZAHNRADANGETRIEBENE NEBENAGGREGATE-WAHLWEISE
QDHK0903 ● QDHK0856
ANSAUGKRUEMMER
TBHK0555
AUSPUFFKRUEMMER
UBHK0347
KRAFTSTOFF-NIEDERDRUCKANLAGE
VBHK1393
KALTSTARTANLAGE
WDHK0195
MOTORHEBEOESEN
XBHK0308

PAGE

14
18
19
20
23
24
25
26
27
28
29
31
32
33
34
36
37

ZUBEHOER

GAS-UND ABSTELLHEBERL
ZAHK0519
OELDRUCKSCHALTER UND OELDRUCKMANOMETER
ZJHK0404
TEMPERATURANZEIGER UND-GEBER
ZLHK0180
WASSERKUEHLER UND LEITBLECH
ZMHK0249
TACHOMETER UND STUNDENZAehler
ZQHK0529
GERAETEZUBEHOER UND NEBENAGGREGATE
ZZHK0386
DICHTRINGE UND DICHTUNGEN KOMPL.REP.-SATZ
SGBK0012

PAGE

3:
3:
4:
4:
4:
4:
4:

SEZIONE PARTI INTERNE**MOTORE ALLEGGERITO**

ACEK6370

MONOBLOCCO

ACHK0018

ALBERO A MANOVELLA-BIELLE E PISTONI

ACHK0018

TESTATA

ACHK0018

ASSE A BILANCIERI

ACHK0018

INGRANAGGI E ALBERO DELLA DISTRIBUZIONE

ACHK0018

POMPA LUBRIFICAZIONE E CARCASSA

ACHK0018

PAGE

1

2

4

6

8

9

13

SEZIONE PARTI A RICHIESTA**EQUIPAGGIAMENTO INIEZIONE NAFTA (DIESEL)**

AFHK2081

CARCASSA VOLANO

CDHK0754

VOLANO E CORONA AVVIAMENTO

DDHK0818

MOTORINO AVVIAMENTO

EDHK0611

COPPA OLIO

GBHK1379

TAPPO RIEMPIMENTO E SFIATATOIO

HBHK1389

FILTRO OLIO E REFRIGERATORE INTEGRALE

JBHK1071

TRASMISSIONE ANTERIORE ENTRATA

KBHK0577

POMPA ACQUA, TERMOSTATO E SCAMBIATORE DI CALORE

LBHK1435

VENTOLA E DISTANZIALE

MDHK0817

ALTERNATORE E GENERATORE

NDHK1760

TRASMISSIONE AUSILIARIA A RICHIESTA

ODHK0903 ● QDHK0856

COLLETTORE ASPIRAZIONE

TBHK0555

COLLETTORE DI SCARICO

UBHK0347

SISTEMA NAFTA A BASSA PRESSIONE

VBHK1393

AVVIAMENTO A FREDDO

WDHK0195

SOLLEVAMENTO MOTORE

XBHK0308

PAGE

14

18

19

20

23

24

25

26

27

28

29

31

32

33

34

36

37

SEZIONE ACCESSORI**COMANDO AVVIAMENTO ED ARRESTO**

ZAHK0519

MANO. E INTERRUTTORE PRESSIONE OLIO

ZJHK0404

BULBO E MANOMETRO TEMPERATURA

ZLHK0180

RADIATORE E COPERCHIO

ZMHK0249

TACHIMETRO E CONTAORE

ZQHK0529

APPLICAZIONI VARIE

ZZHK0386

SERLE COMPLETA GUARNIZIONI

SGBK0012

SECCION DE MOTOR BASICO

MOTOR EMBIELADO	
ACEK6370	
BLOQUE-CYLINDROS	
ACHK0018	
CIGUENAL,PISTONES A BIELAS	
ACHK0018	
CULATA	
ACHK0018	
EJE DE BALANCIN	
ACHK0018	
DISTRIBUCION Y EJE DE LEVAS	
ACHK0018	
BOMBA DEL ACEITE Y CARTER DE ALIMENTACION	
ACHK0018	

PAGE

1
2
4
6
8
9
13**SECCION EQUIPO OPCIONES**

EQUIPO DE INYECCION DEL COMBUSTIBLE (DIESEL)	
AFHK2081	
CARTER DEL VOLANTE	
CDHK0754	
VOLANTE Y ARO DE ARRANQUE	
DDHK0818	
ARRANCADOR	
EDHK0811	
CARTER DEL ACEITE LUBRICANTE	
GBHK1379	
RENIFLARD Y LLENADO DEL ACEITE LUBRICANTE	
HBHK1389	
FILTRO Y ENGRADOR INTEGRAL	
JBHK1071	
ENTRADA DEL MANDO DELANTERO	
KBHK0577	
BOMBA DEL AGUA,TERMOSTATO CAMBIADOR DE TEMPERATURA	
LBHK1435	
VENTILADOR Y PROLONGACION	
MDHK0817	
ALTERNADOR Y DINAMO	
NDHK1760	
EQUIPO OPCIONAL DE MANDO AUXILIAR ACCIONADO ENGRANAJES	
QDHK0903 ● QDHK0856	
MULTIPLE DE ADMISION	
TBHK0555	
MULTIPLE DE ESCAPE	
UBHK0347	
SISTEMA DE COMBUSTIBLE A BAJA PRESION-	
VBHK1393	
SISTEMA DE COMBUSTIBLE A BAJA PRESION	
VBHK1393	
SISTEMA DE ARRANQUE EN TIEMPO FRIO	
WDHK0195	
PLACA LEVANTADORAS DEL MOTOR	
XBHK0308	

PAGE

14
18
19
20
23
24
25
26
27
28
29
31
32
33
34
35
36
37**SECCION EQUIPO ACCESORIOS**

PAG

MANDOS DEL ACELERADOR Y PARADA	
ZAHK0519	3
TRANSMISOR E INDICADOR DE LA PRESION DE ACEITE LUB.	3
ZJHK0404	
INDICADOR Y TRANSMISOR DE TEMPERATURA	
ZLHK0180	4
RADIADOR Y CAPO	
ZMHK0249	4
TAQUIMETRO Y CONTADOR DE HORAS	
ZOHK0529	4
EQUIPO MISCELANEO Y AUXILIAR	
ZZHK0386	4
JUNTAS Y EMPAQUETADURAS..JUEGO COMPLETO DE SERVICIO	
SGBK0012	4

K9105 ACHK-001-A

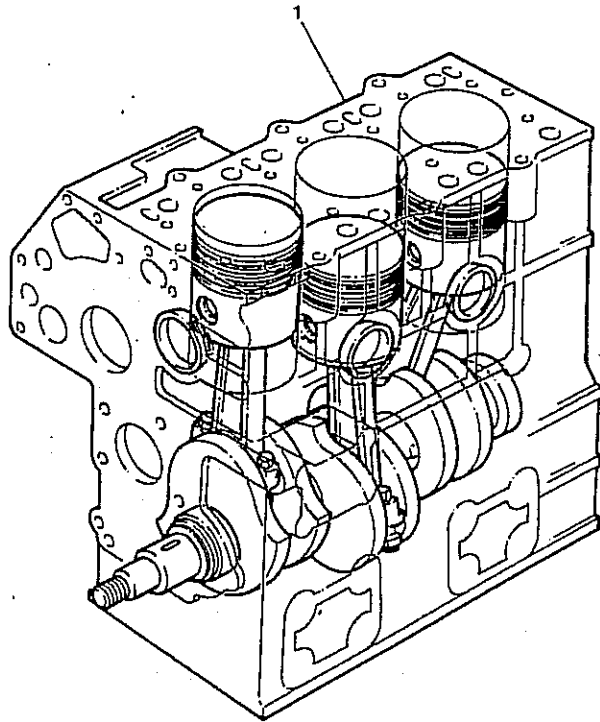

SHORT ENGINE
MOTEUR EMBIELLE
RUMPF MOTOR
MOTORE ALLEGGERITO
MOTOR EMBIELADO

PLATE A
PLAQUE A
PLATTE A
PIASTRA A
PLACA A

ACEK6370

1	110006370	1	Short engine	Bloc embielle Motore allegger.	Rumpfmotor Bloque embielado
2		1 (A)	Cylinder block	Bloc cylindres Monoblocco	Zylinderblock Bloque cilindros
2		1	Crankshaft	Vilbrequin Albero a gomiti	Kurbelwelle Ciguenal
2		1	Piston	Piston Pistone	Kolben Piston
2		1	Piston ring	Segment piston Fascia elastica	Kolbenring Aro de piston
2		1	Conrod	Bielle Biella	Pleuel Biela
2		1	Main bearing	Roulement princ Bronzine princip	Hauptlager Cojinetes princip
2		1	Big end bearing	Roulement extrem Bronzine finali	Pleuellager. Coj.cab.biela
2		1	Thrust washer	Rondelle butee Rondella reggisp	Anlaufscheibe Arandela aceler

(A) COMPLETE WITH PLUGS
AVEC BOUGIES
KOMPLETT MIT STOPFEN
COMPLETO DI TAPPI
INCLUYENDO BUJIAS

K9111 ACHK - 002 - A

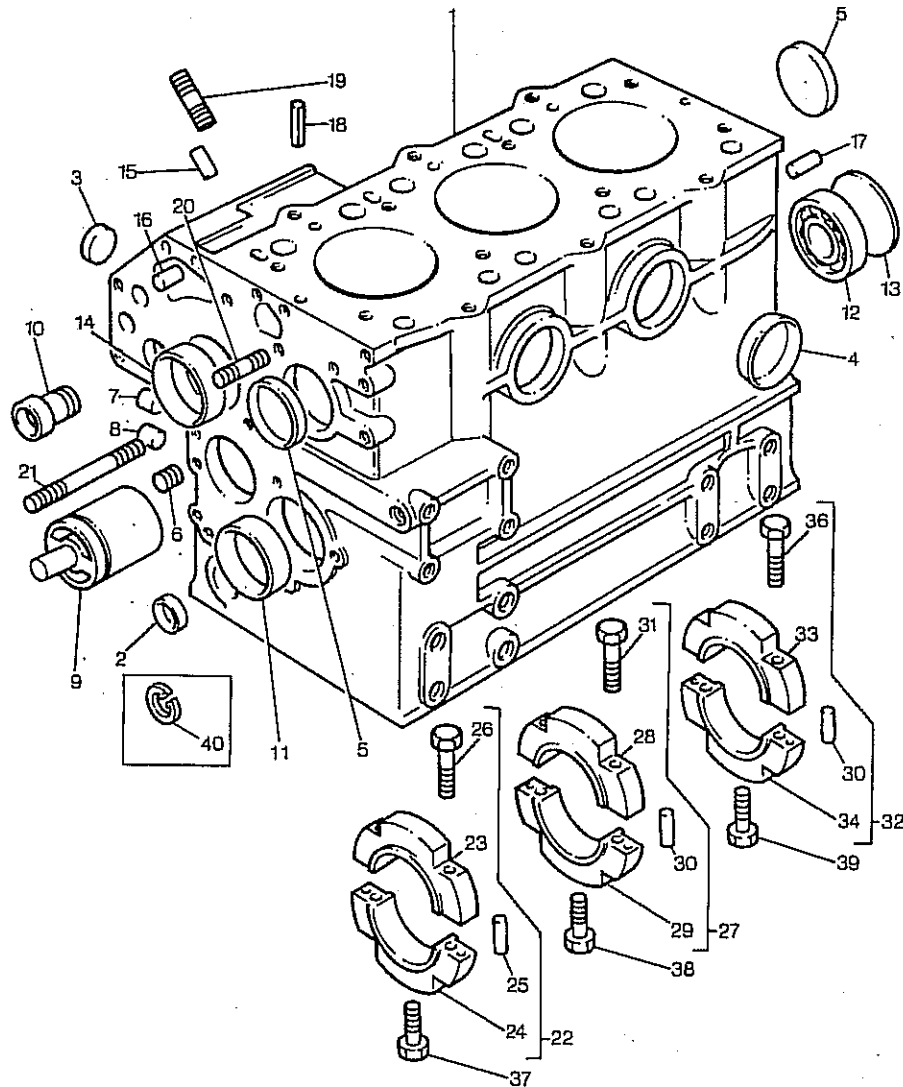

CYLINDER BLOCK
 BLOC-CYLINDRES
 ZYLINDERBLOCK
 MONOBLOCCO
 BLOQUE-CYLINDROS

PLATE A
 PLAQUE A
 PLATTE A
 PIASTRA A
 PLACA A

ACHK0018

1	110186050	110107300	1	Kit,cyl.block	Jeu bloc cylindr Kit,monoblocco	Zyl.blocksatz Jgo.bloque cil.
2	064200015	1	1	Plug	Bouchon Tappo	Verschl.stopfen Tapon
3	064200025	1	1	Plug	Bouchon Tappo	Verschl.stopfen Tapon
4	064200040	1	2	Plug	Bouchon Tappo	Verschl.stopfen Tapon
5	064200040	1	2	Plug	Bouchon Tappo	Verschl.stopfen Tapon
6	198466020	1	3	Plug	Bouchon Tappo	Verschl.stopfen Tapon
7	198466030	1	4	Plug	Bouchon Tappo	Verschl.stopfen Tapon
8	198466010	1	2	Plug	Bouchon Tappo	Verschl.stopfen Tapon
9	165296130	1	1	Shaft	Arbre Albero	Welle Arbol
10	198517090	1	1	Bush	Bague Boccola	Buchse Casquillo
11	198517190	1	1	Bush	Bague Boccola	Buchse Casquillo
11	198517194	X (-)0.25MM	X	Bush	Bague Boccola	Buchse Casquillo
11	198517197	X (-)0.50MM	X	Bush	Bague Boccola	Buchse Casquillo
12	040106203	1	1	Bearing	Coussinet Cuscinetto	Lager Cojinete
13	064100045	1	1	Plug	Bouchon Tappo	Verschl.stopfen Tapon
14	042309013	1	1	Bearing	Coussinet Cuscinetto	Lager Cojinete
15	030500612	1	2	Dowel	Plot Spina	Zylinderstift Centraje
16	030500616	1	2	Dowel	Plot Spina	Zylinderstift Centraje
17	030501025	1	2	Dowel	Plot Spina	Zylinderstift Centraje
18	030309005	1	2	Pin	Goupille Perno	Bolzen Pasador
19	012100820	1	2	Stud	Goujon Prigioniero	Stehbolzen Esparrago
20	012100635	1	1	Stud	Goujon Prigioniero	Stehbolzen Esparrago
21	012100660	1	1	Stud	Goujon Prigioniero	Stehbolzen Esparrago
22	110156161	1	1	Holder	Piece support Supporto di base	Halter Sujetador

K9111 ACHK - 002 - A

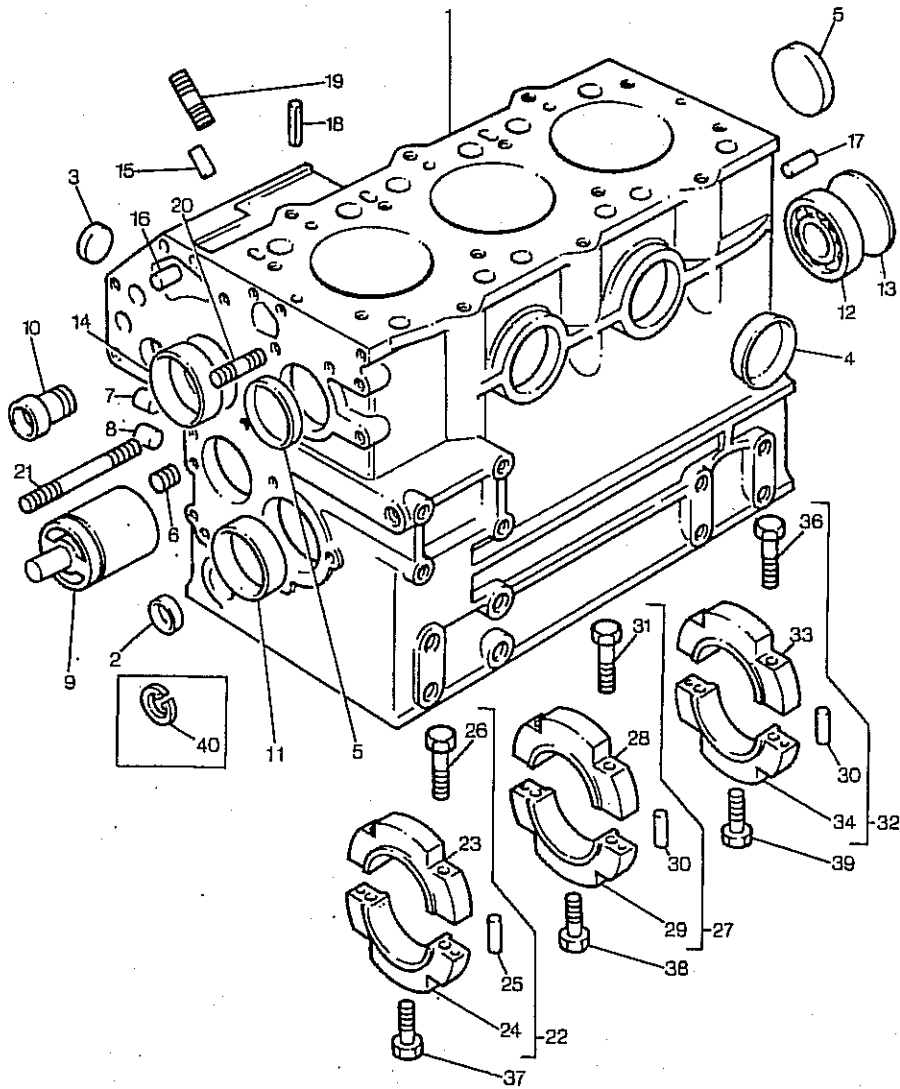

CYLINDER BLOCK
 BLOC-CYLINDRES
 ZYLINDERBLOCK
 MONOBLOCCO
 BLOQUE-CYLINDROS

PLATE A
 PLAQUE A
 PLATTE A
 PIASTRA A
 PLACA A

ACHK0018

23	22	REF.22	1	Cap	Chapeau Cappello	Kappe Tapa
24	22	REF.22	1	Cap	Chapeau Cappello	Kappe Tapa
25	030500612	22	2	Dowel	Plot Spina	Zylinderstift Centraje
26	010111055	22	2	Screw	Vis Vite	Schraube Tornillo
27	110156141	1	1	Holder	Piece support Supporto di base	Halter Sujetador
28	27	REF.27	1	Cap	Chapeau Cappello	Kappe Tapa
29	27	REF.27	1	Cap	Chapeau Cappello	Kappe Tapa
30	030500612	27	2	Dowel	Plot Spina	Zylinderstift Centraje
31	010111055	27	2	Screw	Vis Vite	Schraube Tornillo
32	110156151	1	1	Holder	Piece support Supporto di base	Halter Sujetador
33	32	REF.32	1	Cap	Chapeau Cappello	Kappe Tapa
34	32	REF.32	1	Cap	Chapeau Cappello	Kappe Tapa
35	030500612	32	2	Dowel	Plot Spina	Zylinderstift Centraje
36	010111055	32	2	Screw	Vis Vite	Schraube Tornillo
37	011311070	1	1	Screw	Vis Vite	Schraube Tornillo
38	011311070	1	1	Screw	Vis Vite	Schraube Tornillo
39	010700865	1	2	Screw	Vis Vite	Schraube Tornillo

K9121 ACHK - 003 - A

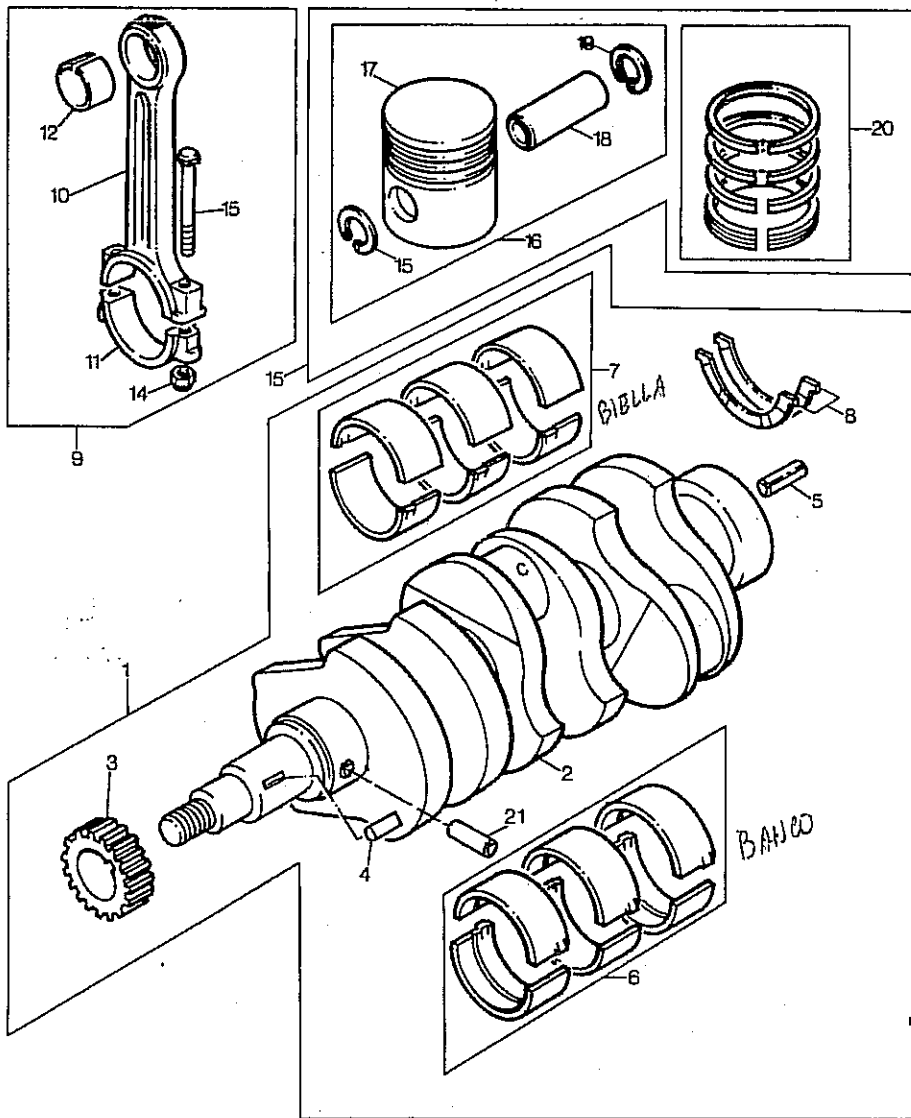

CRANKSHAFT, PISTONS AND CONNECTING RODS
 VILEBREQUIN PISTONS ET BIELLES
 KURBELWELLE, KOLBEN UND PLEUEL
 ALBERO A MANOVELLA-BIELLE E PISTONI
 CIGUENAL, PISTONES A BIELAS

PLATE A
 PLAQUE A
 PLATTE A
 PIASTRA A
 PLACA A

ACHK0018

1	115236030	1	Kit, crankshaft	Jeu vilebrequin Kit alberogomiti	Kurbelwellensatz Ciguenal juego
2		1	REF 1.	Crankshaft	Vilebrequin Albero a gomiti
3	115276200	1	Gear	Engrenage Ingranaggio	Zahnrad Engranaje
4	030509020	1	Key	Clavette Chiavetta	Passkeil Clave
5	030300816	1	Pin	Goupille Perno	Bolzen Pasador
6	198586040	1 (A) STD.	Kit, bearing	Jeu coussinets Kit cuscinetto	Lagersatz Juego cojinetes
6	198586044	(A) X (-)0.25MM	Kit, bearing	Jeu coussinets Kit cuscinetto	Lagersatz Juego cojinetes
6	198586047	(A) X (-)0.50MM	Kit, bearing	Jeu coussinets Kit cuscinetto	Lagersatz Juego cojinetes
7	198586070	1 (A) STD.	Kit, bearing	Jeu coussinets Kit cuscinetto	Lagersatz Juego cojinetes
7	198586074	(A) X (-)0.25MM	Kit, bearing	Jeu coussinets Kit cuscinetto	Lagersatz Juego cojinetes
7	198586077	(A) X (-)0.50MM	Kit, bearing	Jeu coussinets Kit cuscinetto	Lagersatz Juego cojinetes
8	199266190	2	Thrust washer	Rondelle butee Rondella reggisp	Anlaufscheibe Arandela aceler
9	115026211	3	Kit, conrod	Jeu bielle Kit biella	Pleuelst.satz Juego de biela
10		9	REF.9	Rod	Tringle Asta
11		9	REF.9	Cap	Chapeau Cappello
12	198517060	9	198517050	Bush	Bague Boccola
13	115176140	9	2	Screw	Vis Vite
14	020109087	9	2	Nut	Ecrou Dado
15	115016710	STD.	3	Kit, piston	Jeu piston Kit pistone
15	115016714	X (+)0.5MM	X	Kit, piston	Jeu piston Kit pistone
15	115016717	X (+)1.0MM	X	Kit, piston	Jeu piston Kit pistone
16	115016790	15 STD.	3	Kit, piston	Jeu piston Kit pistone
16	115016794	15 X (+)0.5MM	1	Kit, piston	Jeu piston Kit pistone
16	115016797	15 X (+)1.0MM	1	Kit, piston	Jeu piston Kit pistone

K9121 ACHK - 003 - A

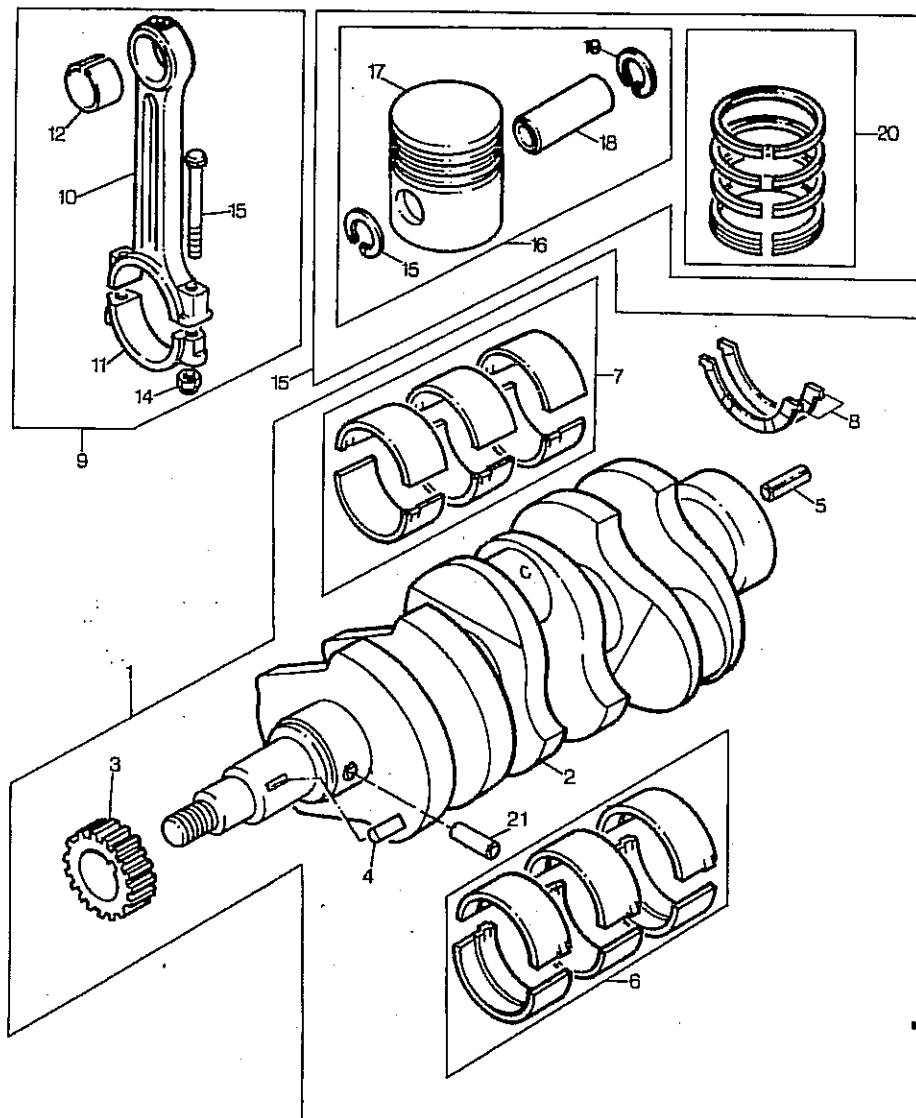

CRANKSHAFT, PISTONS AND CONNECTING RODS
 VILEBREQUIN PISTONS ET BIELLES
 KURBELWELLE, KOLBEN UND PLEUEL
 ALBERO A MANOVELLA-BIELLE E PISTONI
 CIGUENAL, PISTONES A BIELAS

ACHK0018

PLATE A
 PLAQUE A
 PLATTE A
 PIASTRA A
 PLACA A

17	16	REF.15	1	Piston	Pistone	Kolben
18	115326030	16	1	Gudgeon pin	Axe tourillon Spinotto.	Kolbenbolzen. Eje de piston
19	036500025	16	2	Circlip	Segment d arret Anello d'arresto	Sicherungsring Circulito
20	115107290	15 STD.	1	Kit, piston ring	Jeu segm piston Kit fascie elast	Kolbenringsatz Aros.pist.juego
20	115107293	15 I (+)0.5MM	1	Kit, piston ring	Jeu segm piston Kit fascie elast	Kolbenringsatz Aros.pist.juego
20	115107295	15 I (+)1.0MM	1	Kit, piston ring	Jeu segm piston Kit fascie elast	Kolbenringsatz Aros.pist.juego

(A) BEARINGS ARE PRE-FINISHED
 LES COUSSINETS SONT PRE-FINIS
 FERTILAGER
 LE BRONZINE SOND SEMI LAVORATO
 LOS COJINETE SON PREACEBADOS

K9126 ACHK - 004 - A

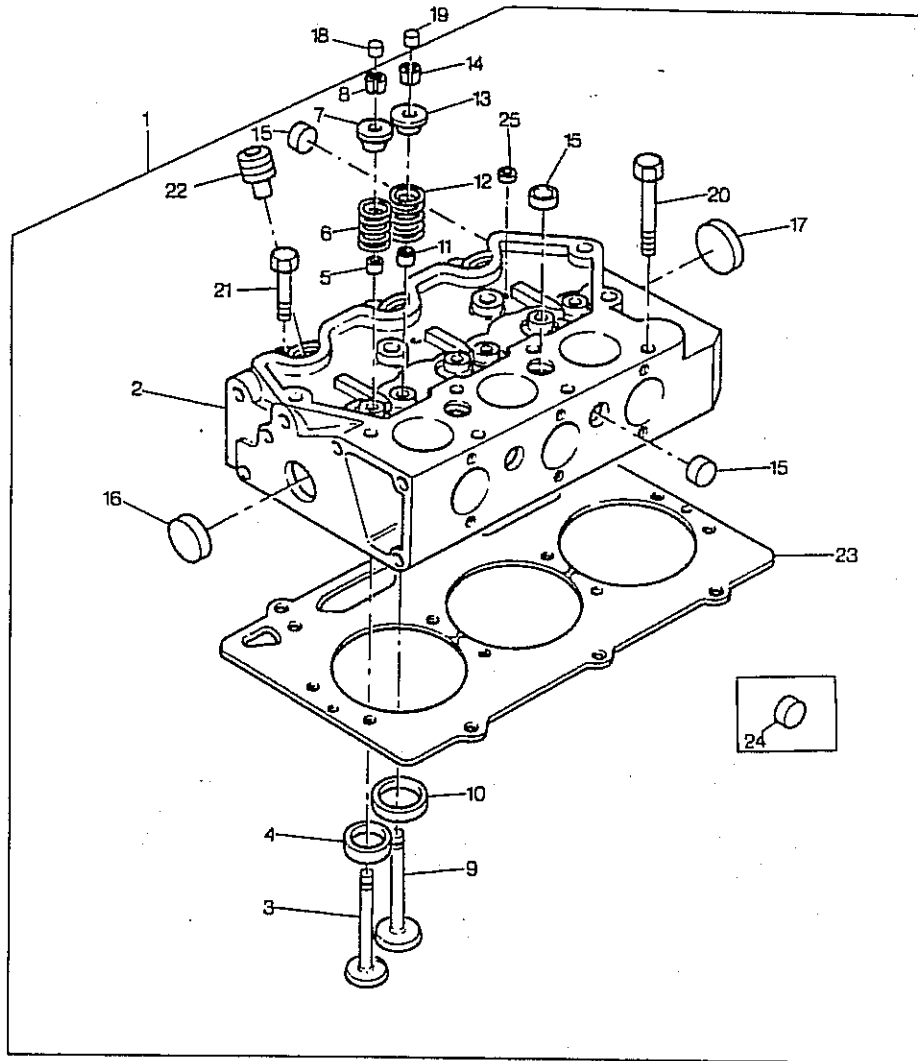

CYLINDER HEAD
CULASSE
ZYLINDERKOPF
TESTATA
CULATA

PLATE A
PLAQUE A
PLATTE A
PIASTRA A
PLACA A

ACHK0018

1	111086050	(A)	1	Kit, cyl. head	Jeu culasse	Zylinderkopfsatz
		● 111017060			Kit testata	Juego de culata
2	111086060	1 (B)	1	Kit, cyl. head	Jeu culasse	Zylinderkopfsatz
					Kit testata	Juego de culata
3	120166270	1	3	Valve inlet	Soupape admiss	Einlassventil
					Valvola immissi.	Valvula admission
4	110136251	1 ● 110136256	3	Insert	Douille	Einsatzstueck
					Inserto	Insercion
5	120406070	1	3	Seal	Bague etancheite	Dichtring
					Paraolio	Reten
6	198216700	1	3	Spring	Ressort	Feder
					Molla	Muelle
7	120186080	1	3	Cap	Chapeau	Kappe
					Cappello	Tapa
8	120226070	1	6	Cotter	Bicone	Splint
					Spinotto	Pasador abierto
9	120176280	1	3	Valve exhaust	Soupape echapp	Auslassventil
					Valvola scarico	Valvula escape
11	120406050	1	3	Seal	Bague etancheite	Dichtring
					Paraolio	Reten
12	198216700	1	3	Spring	Ressort	Feder
					Molla	Muelle
13	120186080	1	3	Cap	Chapeau	Kappe
					Cappello	Tapa
14	120226070	1	6	Cotter	Bicone	Splint
					Spinotto	Pasador abierto
15	064200020	2	5	Plug	Bouchon	Verschl.stopfen
					Tappo	Tapon
16	064200025	2	4	Plug	Bouchon	Verschl.stopfen
					Tappo	Tapon
17	064200030	2	2	Plug	Bouchon	Verschl.stopfen
					Tappo	Tapon
18	120216040	(C)	3	Cap	Chapeau	Kappe
					Cappello	Tapa
19	120216040	(C)	3	Cap	Chapeau	Kappe
					Cappello	Tapa
20	111136360	(C)	11	Screw	Vis	Schraube
					Vite	Tornillo
21	111136370	(C)	3	Screw	Vis	Schraube
					Vite	Tornillo
23	111146991	(C)	1	Gasket	Joint	Dichtscheibe
					Guarnizione	Empaquedatura
24	064200010	2	2	Plug	Bouchon	Verschl.stopfen
					Tappo	Tapon

K9126 ACHK - 004 - A

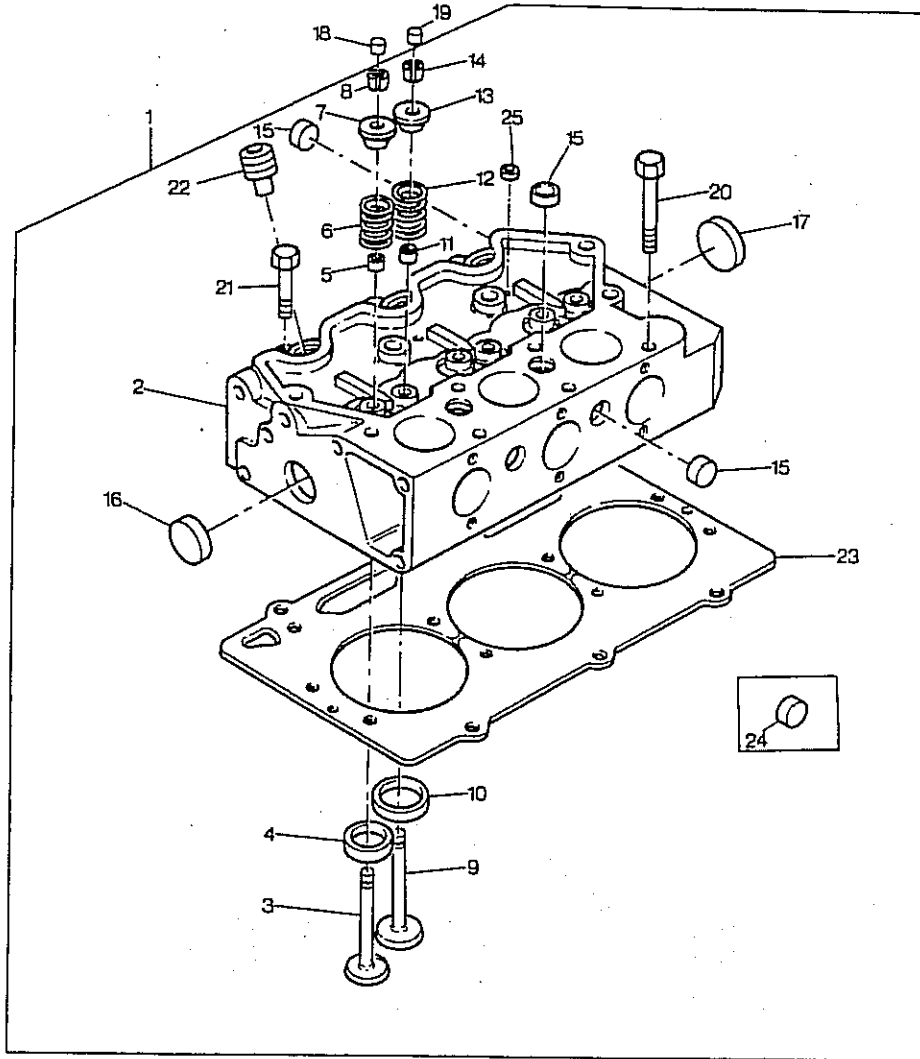

CYLINDER HEAD
CULASSE
ZYLINDERKOPF
TESTATA
CULATA

PLATE A
PLAQUE A
PLATTE A
PIASTRA A
PLACA A

ACHK0018

- (A) MAJOR ASSEMBLY—SEE ITEM 2 FOR MINOR ASSEMBLY
ENSEMBLE PRINCIPAL. VOIR LA REFERENCE NO.2 POUR L'ENSEMBLE MINEUR
GROSSE BAUGRUPPE — SIEHE POS.2 KLEINE BAUGRUPPE
ASSIEME PRINCIPALE VEDERE NO.2 PER ASSIEME SECONDARIO
CONJUNTO PRINCIPAL — VEASE EL RENGLOON NO.2 PARA ELCONJUNTO MENOR
- (B) MINOR ASSEMBLY
ENSEMBLE MINEUR
KLEINE BAUGRUPPE
ASSIEME SECONDARIO
CONJUNTO MENOR
- (C) NOT INCLUDED IN REF.1
NON INCLUS DANS L'ITEM NO.1
NICHT IN POS NR.1
NON INCLUSO IN RIFERIMENTO NO.1
NO SUMINISTRADO EN LA REFERENCIA NO.1

K9132 ACHK-002-B

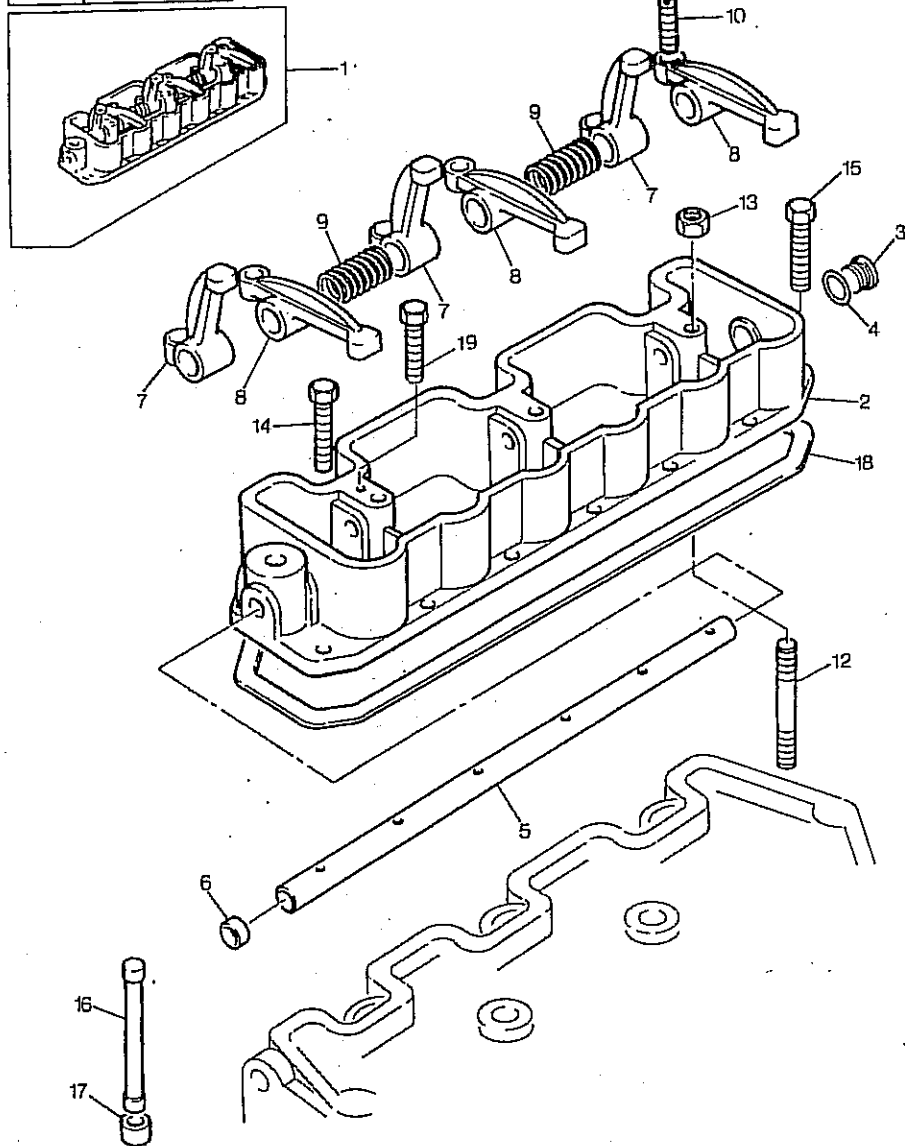

ROCKER SHAFT
 AXE DES CULBUTEURS
 KIPPEBELANLAGE
 ASSE A BILANCIERI
 EJE DE BALANCIN

PLATE B
 PLAQUE B
 PLATTE B
 PIASTRA B
 PLACA B

ACHK0018

1	120336030	● 120036351	1	Rocker shaft ass	Rampe culbuteurs Asse bilancieri	Kipphebelachse Conj.eje balanc
2	120346241	1	1	Bracket	Support fixation Supporto fissagg	Haltearm Soporte
3	198436150	1	1	Plug	Bouchon Tappo	Verschl.stopfen Tapon
4	052100120	1	1	O ring	Joint torique Aneilo or	O-ring Junta torica
5	120316210	1	1	Shaft	Arbre Albero	Welle Arbol
6	064200012	1	1	Plug	Bouchon Tappo	Verschl.stopfen Tapon
7	120366152	1 ▶	3	Lever	Levier Leva	Hebel Palanca
8	120366162	1 ◀	3	Lever	Levier Leva	Hebel Palanca
9	198216780	1	2	Spring	Ressort Molla	Feder Muelle
10	198486220	1	6	Adjusting screw	Vis reglage Vite di regolaz.	Einstellschraube Tornillo ajusta
11	020109076	1	6	Nut	Ecrou Dado	Mutter Tuerca
12	012109177		3	Stud	Goujon Prigioniero	Stehbolzen Esparrago
13	023100008		3	Nut	Ecrou Dado	Mutter Tuerca
14	011300625		1	Screw	Vis Vite	Schraube Tornillo
15	011300635		1	Screw	Vis Vite	Schraube Tornillo
16	120456222		6	Rod	Tringle Asta	Stange Varilla
17	120116160		6	Tappet	Poussoir soupape Punteria	Ventilstoessel Taquet
18	052109065		1	Joint	Joint plat Giunto	Dichtung Junta

K9136 AGHK-001- A

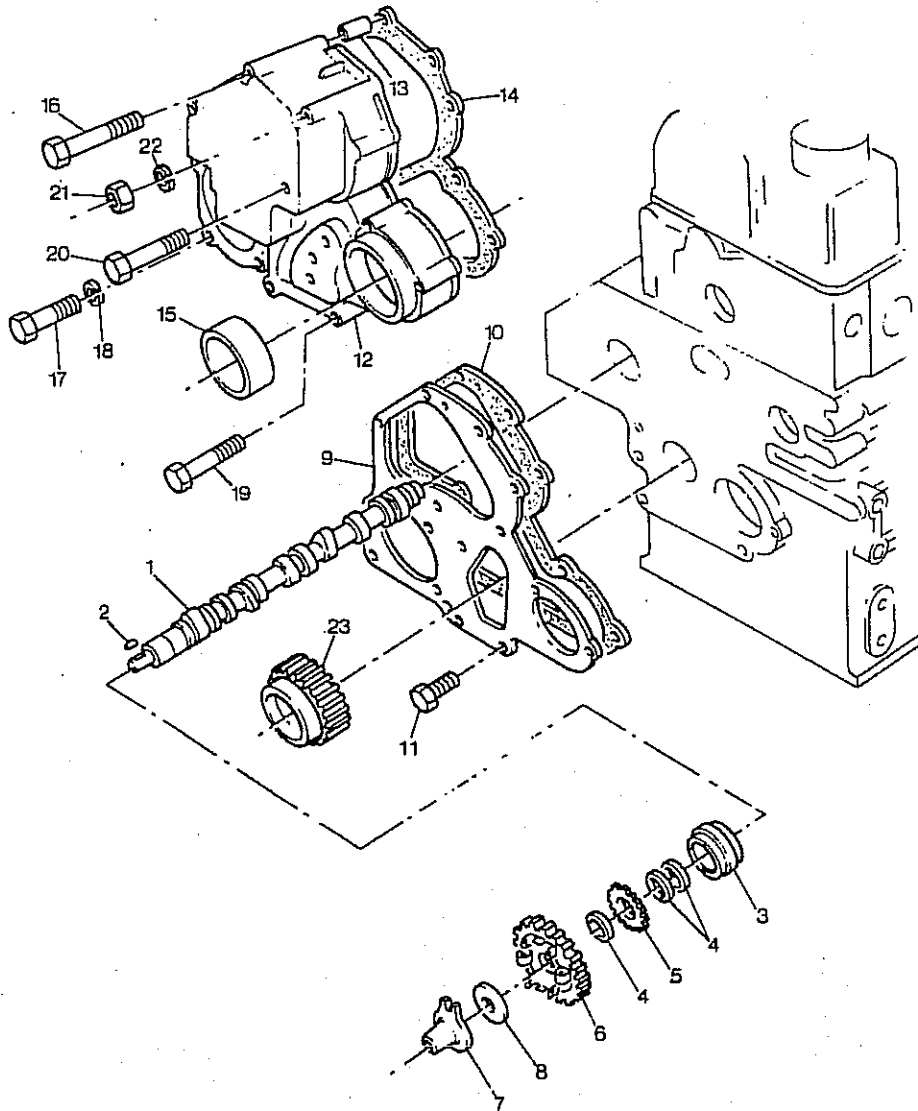

TIMING GEAR AND CAMSHAFT
 DISTRIBUTION ET ARBRE A CAMES
 STEUERGETRIEBE UND NOCKENWELLE
 INGRANAGGI E ALBERO DELLA DISTRIBUZIONE
 DISTRIBUCION Y EJE DE LEVAS

ACHK0018

PLATE A
 PLAQUE A
 PLATTE A
 PIASTRA A
 PLACA A

1	120026190		1	Camshaft.	Arbre a cames Albero a camme	Nockenwelle Arbol de levas
2	034100508	1	1	Key	Clavette Chiavetta	Passkeil Clave
3	040156304	1	1	Bearing	Coussinet Cuscinetto	Lager Cojinete
4	199216230	1	3	Spacer	Entretoise Distanziale	Abstandstueck Pieza distancia
5	120736081	1	1	Gear	Engrenage Ingranaggio	Zahnrad Engranaje
6	120016050	1	1	Gear	Engrenage Ingranaggio	Zahnrad Engranaje
7	125256120		1	Tappet	Poussoir soupape Punteria	Ventilstoessel Taquet
9	165166221		1	Plate	Plaque Piastra	Platte Plato
10	165996361		1	Joint	Joint plat Giunto	Dichtung Junta
11	011300612		2	Bolt	Boulon Bullone	Masch.schraube Perno
* 12	165106092	● 165106091 ● 165106220	1	Case	Caissette Cassa	Kasten Estuche
13	030300414	12	1	Pin	Goupille Perno	Bolzen Pasador
14	165996351		1	Gasket	Joint Guarnizione	Dichtscheibe Empaquedatura
15	198636160		1	Seal	Bague etancheite Paraolio	Dichtring Reten
16	011300645		6	Screw	Vis Vite	Schraube Tornillo
17	011300860	(B)	4	Screw	Vis Vite	Schraube Tornillo
19	011300680		2	Screw	Vis Vite	Schraube Tornillo
20	011300660		5	Screw	Vis Vite	Schraube Tornillo
21	023100006		1	Nut	Ecrou Dado	Mutter Tuerca
23		(A)	1	Gear	Engrenage Ingranaggio	Zahnrad Engranaje

(A) SEE LUB OIL PUMP SECTION
 VOIR LA SECTION POMPE A HUILE
 SIEHE SCHMIEROELPUMPE
 VEDERE SEZIONE DE POMPA LUBRIFICAZIONE
 VER LA SECCION DEL BOMBA DEL ACEITE

K9136 ACHK-001- A

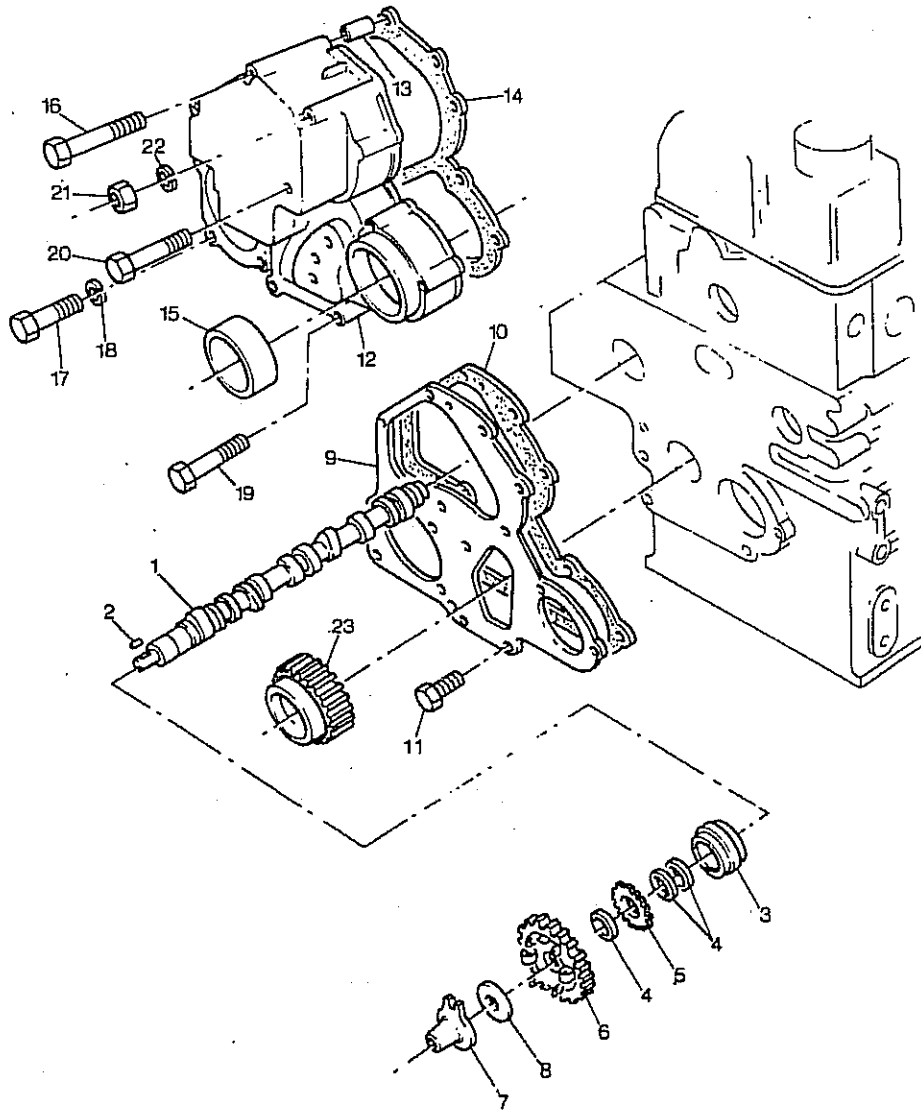

TIMING GEAR AND CAMSHAFT
DISTRIBUTION ET ARBRE A CAMES
STEUERGETRIEBE UND NOCKENWELLE
INGRANAGGI E ALBERO DELLA DISTRIBUZIONE
DISTRIBUCION Y EJE DE LEVAS

ACHK0018

PLATE A
PLAQUE A
PLATTE A
PIASTRA A
PLACA A

- (B) USED ONLY WITH 165106220.
EMPLOYEE SEULEMENT AVEC 165106220.
NUR FUER 165106220.
USATO SOLO CON 165106220.
EMPLEADA SOLAMENTE CON 165106220.

K8137 ACHK-002-B

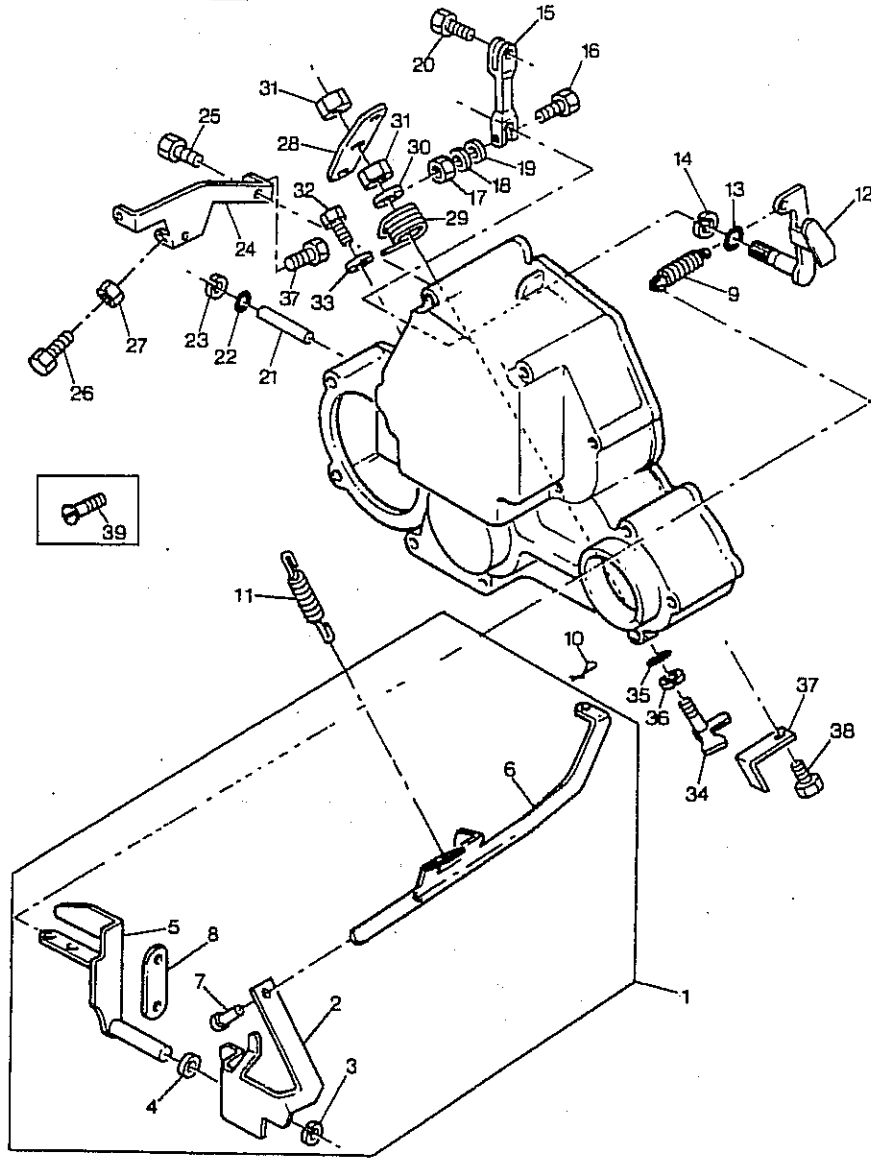

TIMING GEAR AND CAMSHAFT
 DISTRIBUTION ET ARBRE A CAMES
 STEUERGETRIEBE UND NOCKENWELLE
 INGRANAGGI E ALBERO DELLA DISTRIBUZIONE
 DISTRIBUCION Y EJE DE LEVAS

ACHK0018

PLATE B
 PLAQUE B
 PLATTE B
 PIASTRA B
 PLACA B

1	125046150	1	Lever	Levier	Hebel
2	1 REF.1	1	Lever	Leva	Palanca
3	036800008	1	Circlip	Segment d arret	Sicherungsring
4	026200010	1	Washer	Anello d'arresto	Circulito
5	125406080	1	Lever	Rondelle	Unterlegscheibe
6	1 REF.1	1	Link	Arandella	Arandella
7	1 REF.1	1	Pin	Levier	Hebel
9	198217110	1	Spring	Leva	Palanca
10	031100004	1	Pin	Maillon	Glief
11	198216731	1	Spring	Maglia	Union
12	125156170	1	Arm	Goupille	Bolzen
13	052100070	1	O ring	Perno	Pasador
14	036800008	1	Circlip	Ressort	Feder
15	125416020	1	Lever	Molla	Muelle
16	010100630	1	Screw	Goupille	Bolzen
17	023100006	1	Nut	Perno	Pasador
21	125116140	1	Shaft	Ressort	Feder
22	052100030	1	O ring	Molla	Muelle
23	036800005	1	Circlip	Bras	Arm
24	125976120	1	Stay	Braccio	Braccio
25	011300616	2	Screw	Joint torique	O-ring
26	010109264	2	Screw	Anello or	Junta torica
27	023100006	2	Nut	Segment d arret	Sicherungsring
28	125176080	1	Lever	Anello d'arresto	Circulito
				Hauban	Strebe
				Busto	Tirante
				Vis	Schraube
				Vite	Tornillo
				Vis	Schraube
				Vite	Tornillo
				Ecrou	Mutter
				Dado	Tuerca
				Levier	Hebel
				Leva	Palanca

K9137 ACHK-002-B

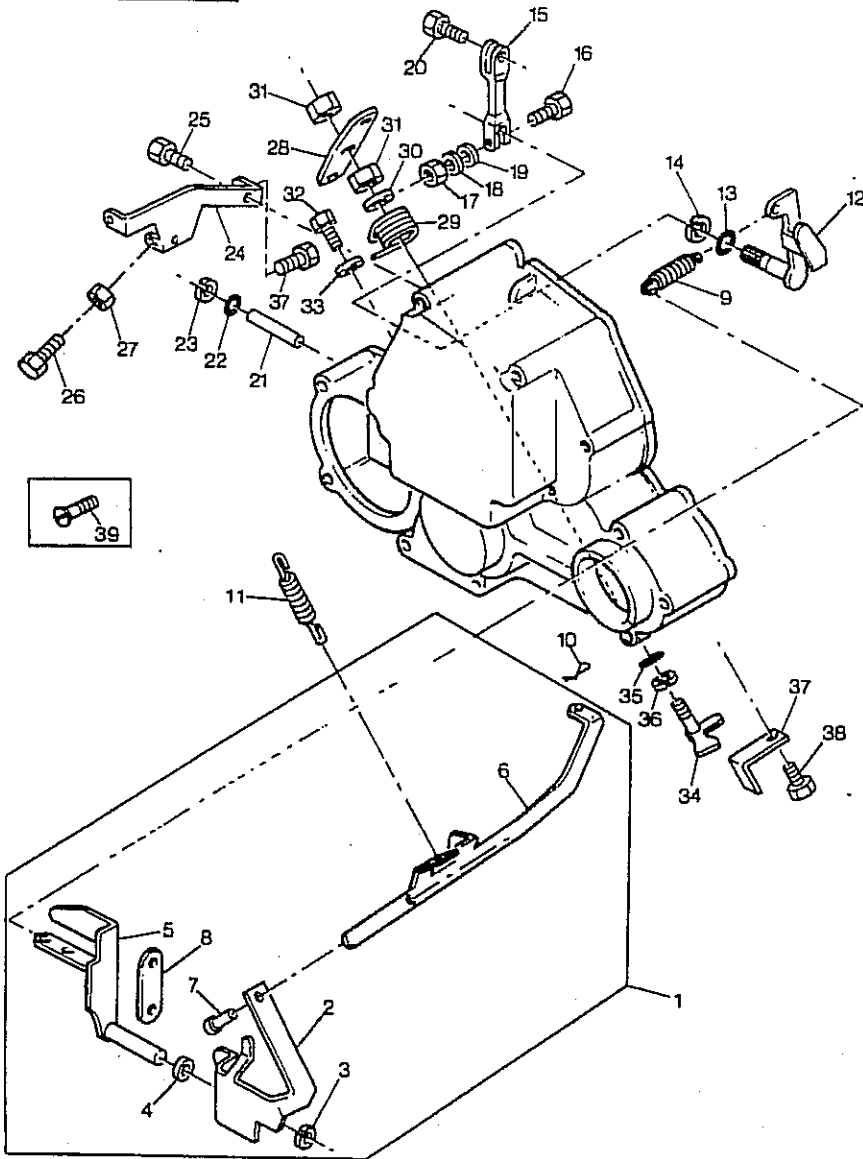

TIMING GEAR AND CAMSHAFT
 DISTRIBUTION ET ARBRE A CAMES
 STEUERGETRIEBE UND NOCKENWELLE
 INGRANAGGI E ALBERO DELLA DISTRIBUZIONE
 DISTRIBUCION Y EJE DE LEVAS

ACHK0018

PLATE B
 PLAQUE B
 PLATTE B
 PIASTRA B
 PLACA B

29	198216760	1	Spring	Ressort Molla	Feder Mueller
30	026200008	1	Washer	Rondelle Rondella	Unterlegscheibe Arandela
31	020300008	2	Nut	Ecrou Dado	Mutter Tuerca
34	125156180	1	Arm	Bras Braccio	Arm Brazo
35	052100050	1	O ring	Joint torique Anello or	O-ring Junta torica
36	036800006	1	Circlip	Segment d arret Anello d'arresto	Sicherungsring Circulito

K9151 ACHK-002-A

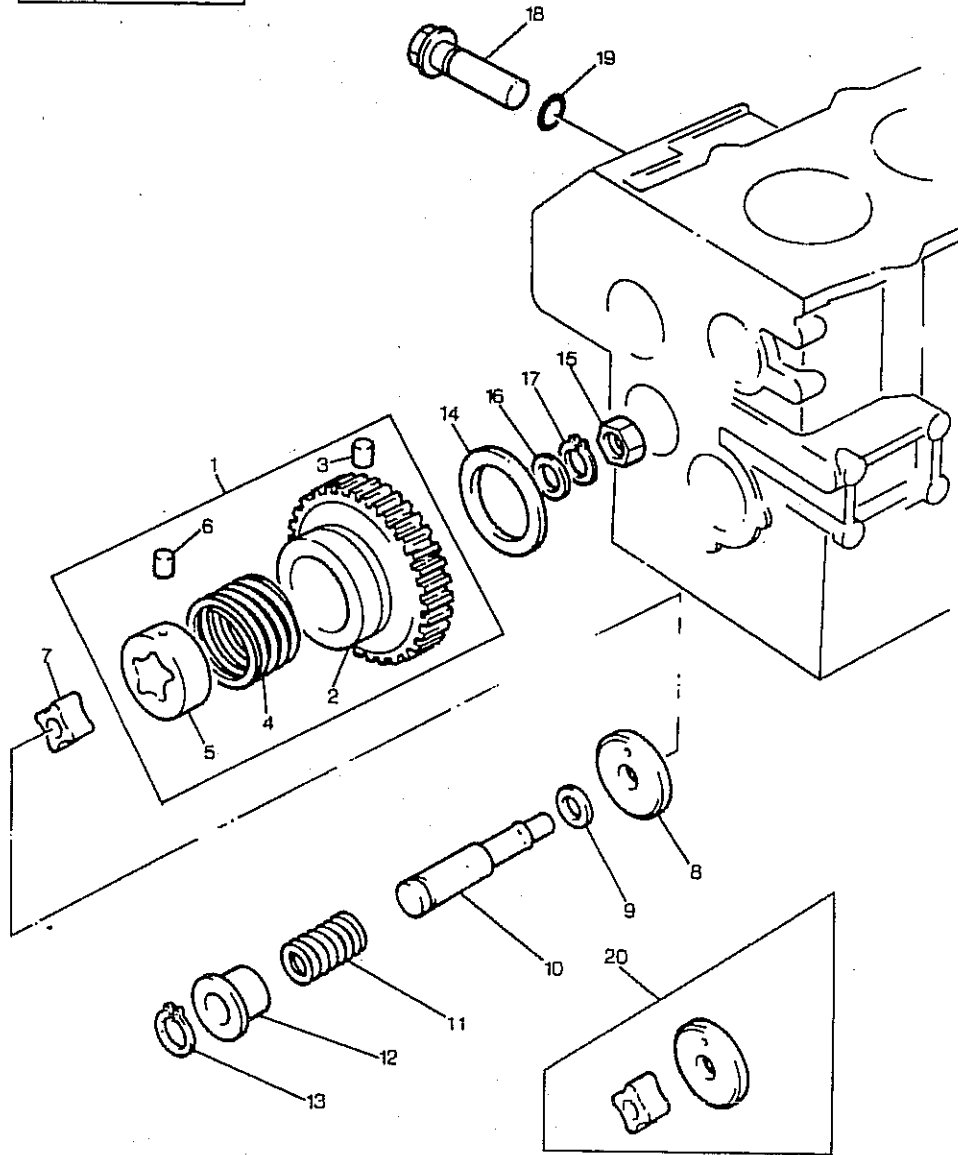

LUBRICATING OIL PUMP AND DELIVERY HOUSING
 POMPE A HUILE ET CLAPET DE DECHARGE
 SCHMIEROELPUMPE UND ENTLASTUNGSVENTIL
 POMPA LUBRIFICAZIONE E CARCASSA
 BOMBA DEL ACEITE Y CARTER DE ALIMENTACION

ACHK0018

PLATE A
 PLAQUE A
 PLATTE A
 PIASTRA A
 PLACA A

1	165026120		1	Gear	Engrenage Ingranaggio	Zahnrad Engranaje
4	198216821	1	1	Spring	Ressort Molla	Feder Muelle
7	140166140		1	Rotor	Rotor Rotore	Rotor Rotor
8	140116140		1	Cover	Couvercle Coperchio	Deckel Cubierta
9	199286150	± (+)0.10MM	X	Shim	Cale réglage Spessore	Einstellblech Calce
9	199286160	± (+)0.15MM	X	Shim	Cale réglage Spessore	Einstellblech Calce
9	199286170	± (+)0.20MM	X	Shim	Cale réglage Spessore	Einstellblech Calce
9	199286180	± (+)0.50MM	X	Shim	Cale réglage Spessore	Einstellblech Calce
11	198216720		1	Spring	Ressort Molla	Feder Muelle
12	199236540		1	Collar	Collerette Collare	Flanschring Collar
13	036800010		1	Circlip	Segment d arret Anello d'arresto	Sicherungsring Circulito
14	199266180		1	Washer	Rondelle Rondella	Unterlegscheibe Arandella
18	140036120		1	Valve	Soupape Valvola	Ventil Valvula
19	052100150		1	O ring	Joint torique Anello or	O-ring Junta torica
20	140186020		X	Kit, repair	Jeu reparation Kit riparazione	Reparaturatz Juego reparacion

K9166 AFHK-002-A

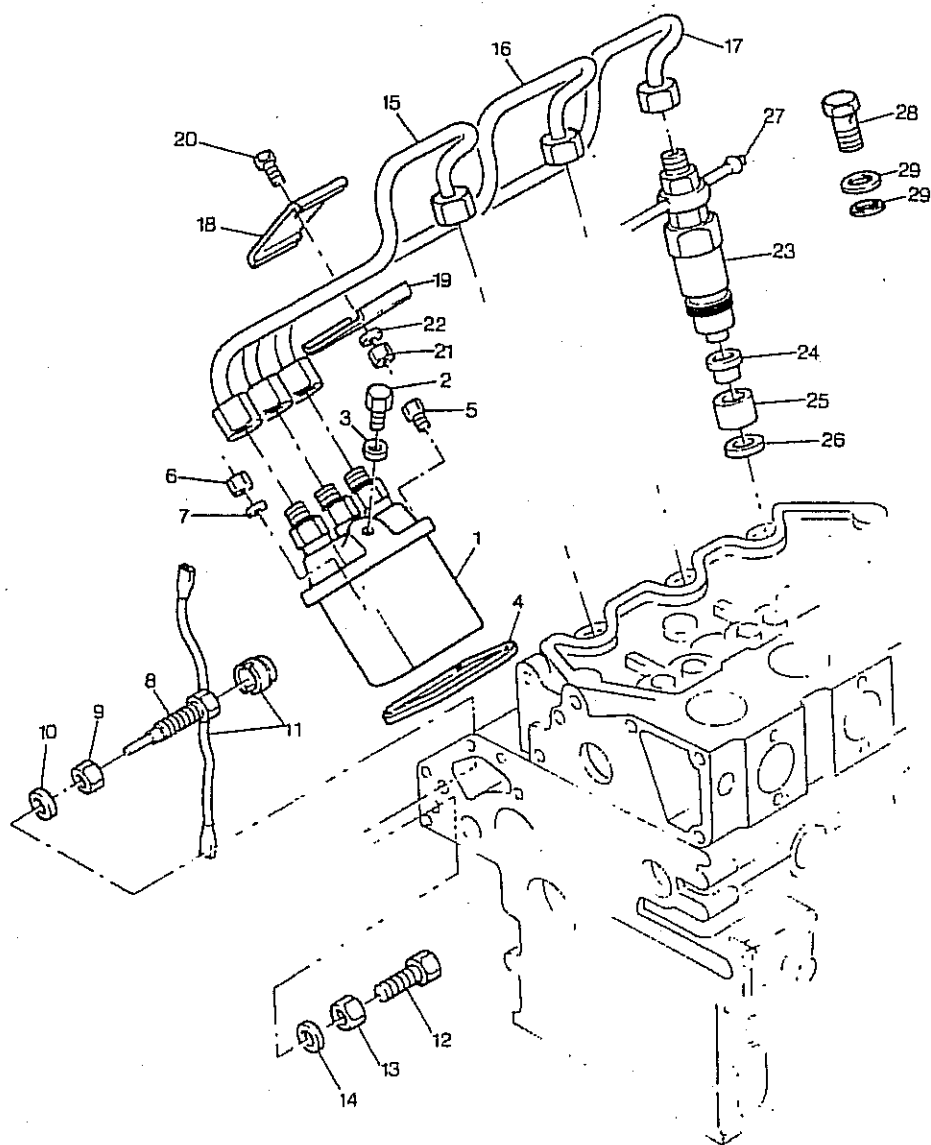

FUEL INJECTION EQUIPMENT (DIESEL)
 EQUIPEMENT D'INJECTION (DIESEL)
 EINSPRITZANLAGE (DIESEL)
 EQUIPAGGIAMENTO INIEZIONE NAFTA (DIESEL)
 EQUIPO DE INYECCION DEL COMBUSTIBLE (DIESEL)
 AFHK2081

PLATE A
 PLAQUE A
 PLATTE A
 PIASTRA A
 PLACA A

1	131017360	(A)	1	Injection pump	Pompe injection Pompa iniezione	Einspritzpumpe Bomba inyectora
2	131136350		1	Screw	Vis Vite	Schraube Tornillo
3	025100008		1	Washer	Rondelle Rondella	Unterlegscheibe Arandela
4	131437300	X (+)0.2MM	X	Shim	Cale reglage Spessore	Einstellblech Calce
4	131437301	X (+)0.3MM	X	Shim	Cale reglage Spessore	Einstellblech Calce
4	131426310	X (+)0.5MM	X	Shim	Cale reglage Spessore	Einstellblech Calce
4	131437303	X (+)1.0MM	X	Shim	Cale reglage Spessore	Einstellblech Calce
5	011300820		2	Screw	Vis Vite	Schraube Tornillo
6	023100008		2	Nut	Ecrou Dado	Mutter Tuerca
7	027109010		2	Washer	Rondelle Rondella	Unterlegscheibe Arandela
8	131046120		1	Screw	Vis Vite	Schraube Tornillo
9	023109002		1	Nut	Ecrou Dado	Mutter Tuerca
10	025100010		1	Washer	Rondelle Rondella	Unterlegscheibe Arandela
11	198236030		1	Wire	Fil Filo di ferro	Draht Hilo
12	010109270		1	Screw	Vis Vite	Schraube Tornillo
13	023109002		1	Nut	Ecrou Dado	Mutter Tuerca
14	025100010		1	Washer	Rondelle Rondella	Unterlegscheibe Arandela
15	131507100	NO.1 CYL.	1	Injection pipe	Tuyau injection Tubo iniezione	Einspritzleitung Tubo d inyeccion
16	131507110	NO.2 CYL.	1	Injection pipe	Tuyau injection Tubo iniezione	Einspritzleitung Tubo d inyeccion
17	131507120	NO.3 CYL.	1	Injection pipe	Tuyau injection Tubo iniezione	Einspritzleitung Tubo d inyeccion
18	199106020		2	Damper	Damper s poulie Ammortizzatore	Daempfer Valv.reguladora
19	199106020		2	Damper	Damper s poulie Ammortizzatore	Daempfer Valv.reguladora
20	010100625		2	Screw	Vis Vite	Schraube Tornillo
21	023100006		2	Nut	Ecrou Dado	Mutter Tuerca

K9166 AFHK-002-A

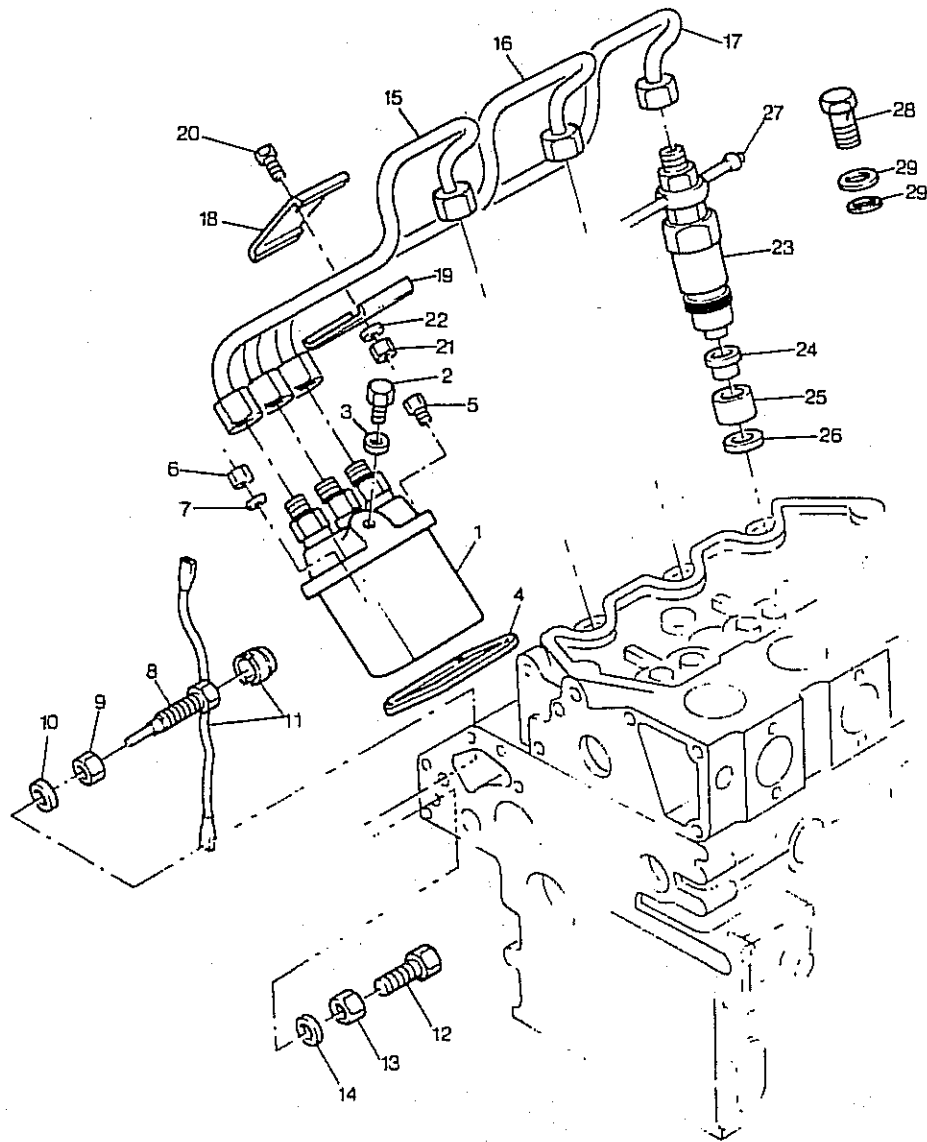

FUEL INJECTION EQUIPMENT (DIESEL)
 EQUIPEMENT D'INJECTION (DIESEL)
 EINSPRITZANLAGE (DIESEL)
 EQUIPAGGIAMENTO INIEZIONE NAFTA (DIESEL)
 EQUIPO DE INYECCION DEL COMBUSTIBLE (DIESEL)
 AFHK2081

PLATE A
 PLAQUE A
 PLATTE A
 PIASTRA A
 PLACA A

23	131406360	(A)	3	Atomiser	Injecteur	Zerstaeuber
26	131426200		3	Gasket	Atomizzatore	Atomizador
27	131606290		1	Leak-off pipe	Joint	Dichtscheibe
					Guarnizione	Empaquetadura
					Tuyauterie fuite	Leckoel-leitung
					Tubo drenaggio	Tubo de escape.

(A) SEE FOLLOWING PARTS LIST FOR SERVICE COMPONENTS
 VOIR CHAPITRE SUIVANT POUR DETAILS
 FUER SERVICETEILE S.NACHFOLGENDE E.T.LISTE
 VEDERE DI SEGUITO PER COMPONENTI SERVINILI
 VEASE LA LISTA DE PIEZAS QUE SIGUE PARA LOS COMPONENTES DE SERVICIO

K 9168 AFHK-002-C

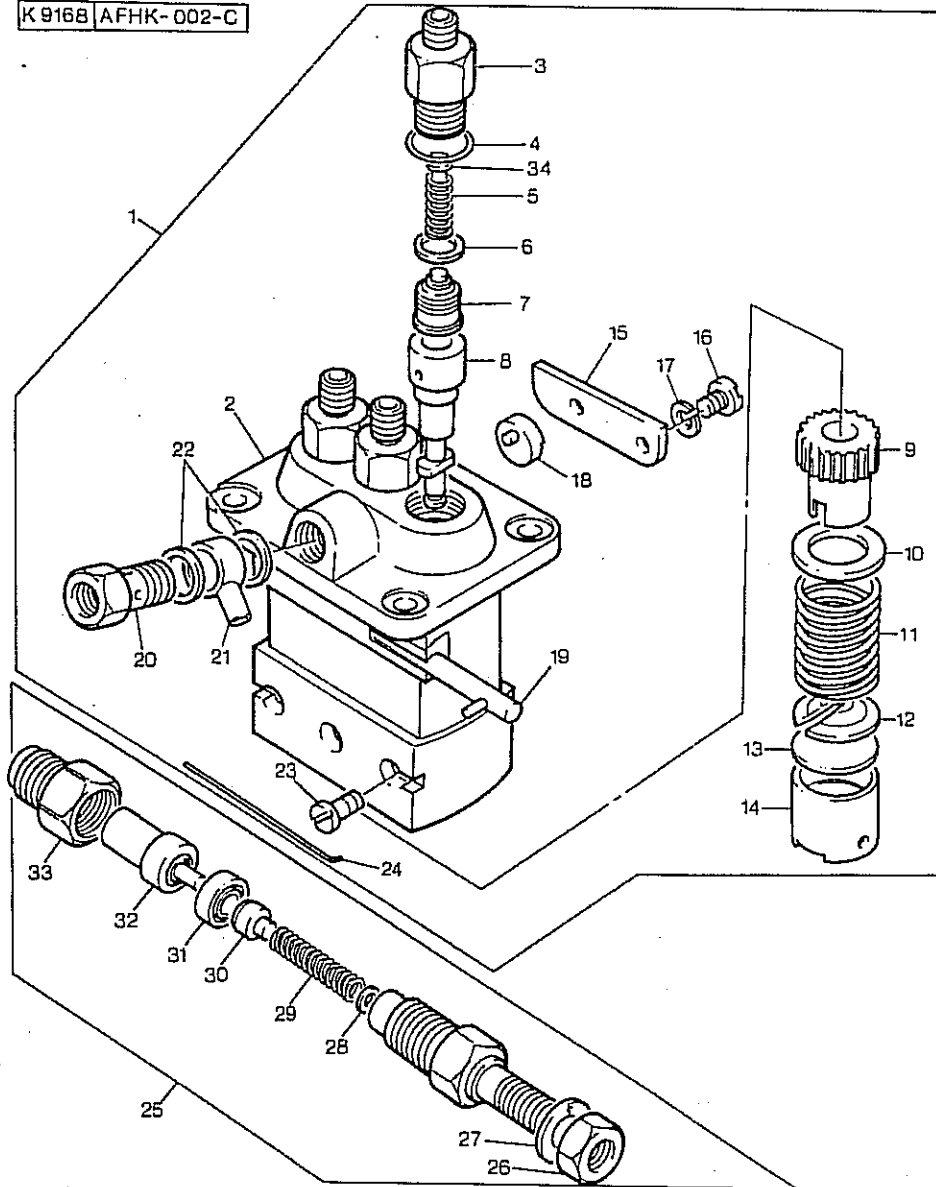

FUEL INJECTION EQUIPMENT (DIESEL)
 EQUIPEMENT D'INJECTION (DIESEL)
 EINSPRITZANLAGE (DIESEL)
 EQUIPAGGIAMENTO INIEZIONE NAFTA (DIESEL)
 EQUIPO DE INYECCION DEL COMBUSTIBLE (DIESEL)
 AFHK2081

PLATE C
 PLAQUE C
 PLATTE C
 PIASTRA C
 PLACA C

1	131017360	1	Injection pump	Pompe injection	Einspritzpumpe
2	1 REF.1	1	Body	Pompa iniezione	Bomba inyectora
* 3	131196060 1 131916060	3	Holder	Corps	Koerper
4	131226130 1	3	O ring	Corpo	Cuerpo
5	131176450 1	3	Spring	Piece support	Halter
6	131186110 1	3	Gasket	Supporto di base	Sujetador
7	131156150 1	3	Valve	Joint torique	O-ring
8	131116380 1	3	Element	Anello or	Junta torica
9	131296647 1	3	Sleeve	Ressort	Feder
10	131296532 1	3	Washer	Molla	Muelle
11	131176320 1	3	Spring	Joint	Dichtscheibe
12	131296531 1	3	Washer	Guarnizione	Empaquedatura
13	131296530 1	X	Plate	Soupape	Ventil
14	131256110 1	3	Tappet	Valvola	Valvula
15	131296649 1	1	Cover	Element	Elemento
16	131296408 1	2	Screw	Manchon	Huelse
17	131146070 1	2	Washer	Manicotto	Mancha
18	131296648 1	1	Pin	Rondelle	Unterlegscheibe
19	131296678 1	1	Rack	Rondella	Arandela
20	131246170 1	1	Bolt	Ressort	Feder
21	131246010 1	1	Connection	Molla	Muelle
22	131296255 1	2	Gasket	Rondelle	Unterlegscheibe
23	131296645 1	1	Pin	Rondella	Arandela
25	131406360 1	1	Atomiser	Plaque	Platte
				Piastra	Plato
				Poussoir soupape	Ventilstoessel
				Punteria	Taquet
				Couvercle	Deckel
				Coperchio	Cubierta
				Vis	Schraube
				Vite	Tornillo
				Rondelle	Unterlegscheibe
				Rondella	Arandela
				Goupille	Bolzen
				Perno	Pasador
				Cremailiere	Zahnstange
				Cremagliera	Barra dentada
				Boulon	Masch.schraube
				Bullone	Perno
				Connexion	Verbindung
				Connessione	Conexion
				Joint	Dichtscheibe
				Guarnizione	Empaquedatura
				Goupille	Bolzen
				Perno	Pasador
				injecteur	Zerstaeuber
				Atomizzatore	Atomizador

K 9168 AFHK-002-C

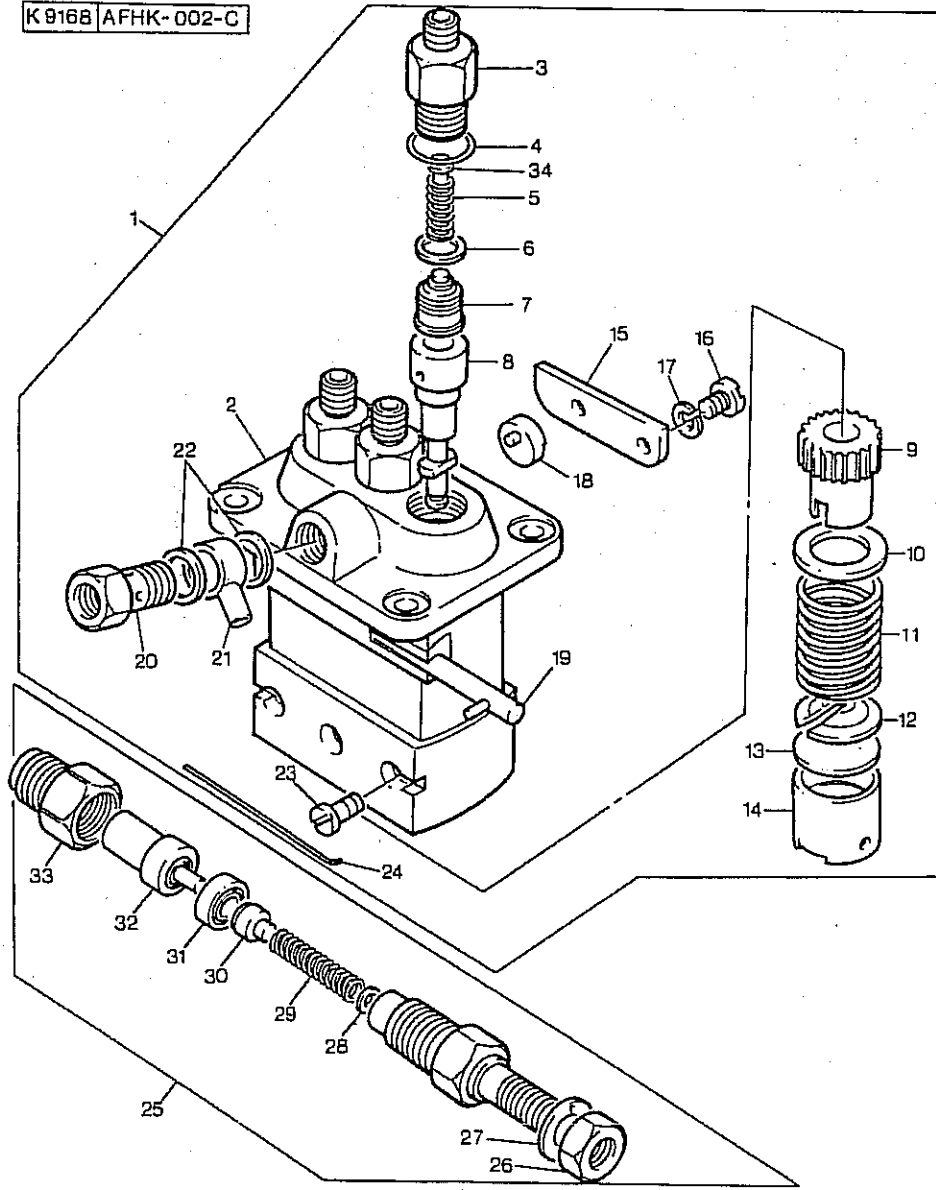

FUEL INJECTION EQUIPMENT (DIESEL)
 EQUIPEMENT D'INJECTION (DIESEL)
 EINSPRITZANLAGE (DIESEL)
 EQUIPAGGIAMENTO INIEZIONE NAFTA (DIESEL)
 EQUIPO DE INYECCION DEL COMBUSTIBLE (DIESEL)
 AFHK2081

PLATE C
 PLAQUE C
 PLATTE C
 PIASTRA C
 PLACA C

26	131446006	25	1	Nut	Ecrou	Mutter
27	131426230	25	1	Gasket	Dado	Tuerca
28	131437360	25	3	Shim	Joint	Dichtscheibe
29	131446074	25	1	Spring	Guarnizione	Empaquedatura
30	131446075	25	1	Washer	Cale reglage	Einstellblech
31	131446076	25	1	Spacer	Spessore	Calce
32	131416170	25	1	Nozzle	Ressort	Feder
33	131446077	25	1	Nut	Molla	Muelle
44	33856109		1	Hose	Rondelle	Unterlegscheibe
55	0180070		8	Clip	Rondella	Arandela
67	33855125		2	Hose	Entretoise	Abstandstueck
					Distanziale	Pieza distancia
					Nez injecteur	Duese
					Iniettor	Tobera
					Ecrou	Mutter
					Dado	Tuerca
					Durite	Schlauch
					Tubo flessibile	Flexible
					Circlip	Schelle
					Fermaglio	Crapa reten
					Durite	Schlauch
					Tubo flessibile	Flexible

K9206 CDHK-003-A

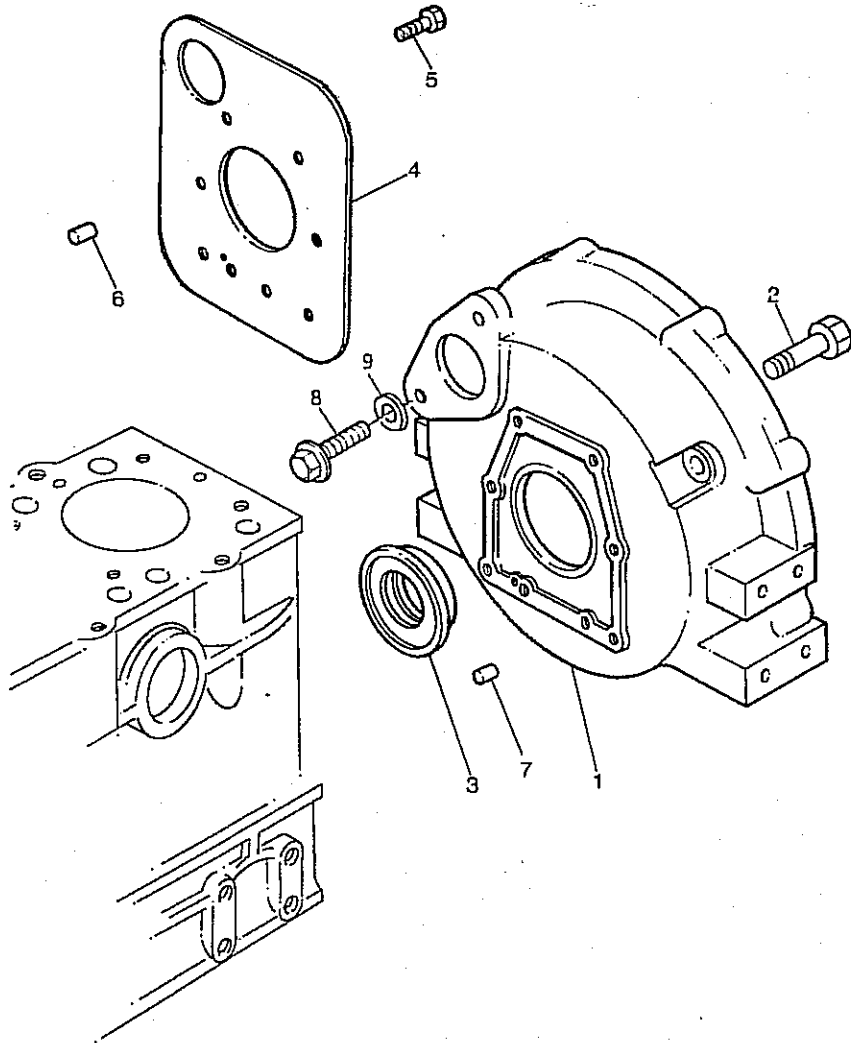

FLYWHEEL HOUSING
 CARTER VOLANT
 SCHWUNGRADGEHAEUSE
 CARCASSA VOLANO
 CARTER DEL VOLANTE

PLATE A
 PLAQUE A
 PLATTE A
 PIASTRA A
 PLACA A

CDHK0754

3	198636170	1	Seal	Bague etancheite Paraolio	Dichtring Reten
4	110366350	1	Plate	Plaque Piastra	Platte Plato
5	011300816	10	Screw	Vis Vite	Schraube Tornillo

K9216 DDHK-001-A

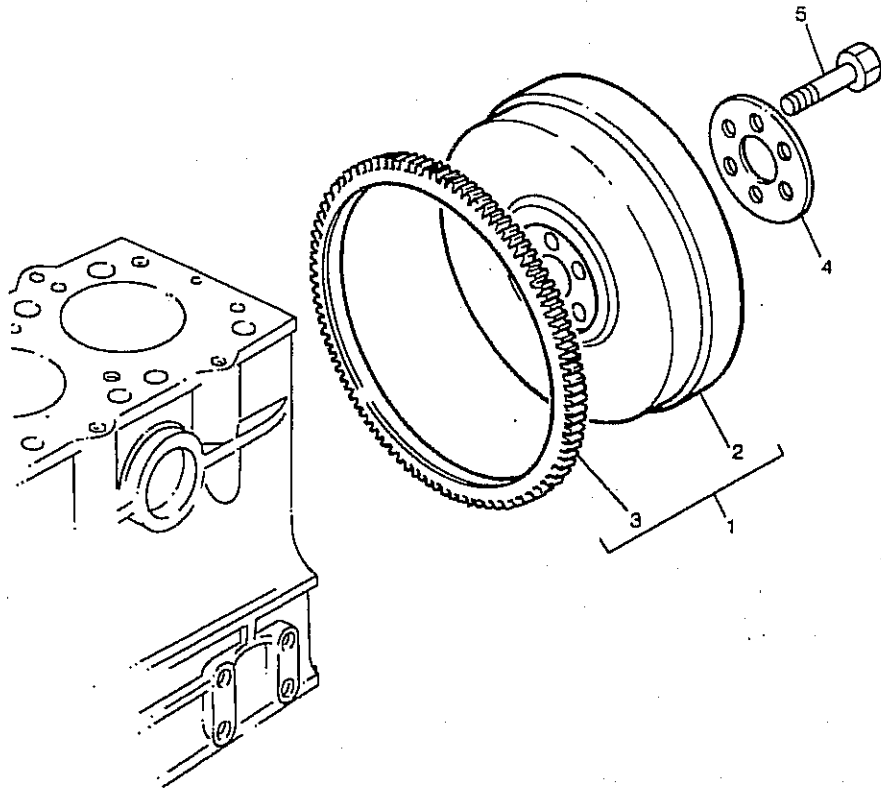

FLYWHEEL AND STARTER RING
VOLANT ET COURONNE DEMARRAGE
SCHWUNGRAD UND ZAHNKRANZ
VOLANO E CORONA AVVIAMENTO
VOLANTE Y ARO DE ARRANQUE

DDHK0818

PLATE A
PLAQUE A
PLATTE A
PIASTRA A
PLACA A

3	115376130	1	Starter ring	Couronne demarr	Anlasszahnkranz
				Corona avviam	Aro de arranque
5	010109341	6	Bolt	Boulon	Masch.schraube
				Bullone	Perno

K9221 EDHK-002-A

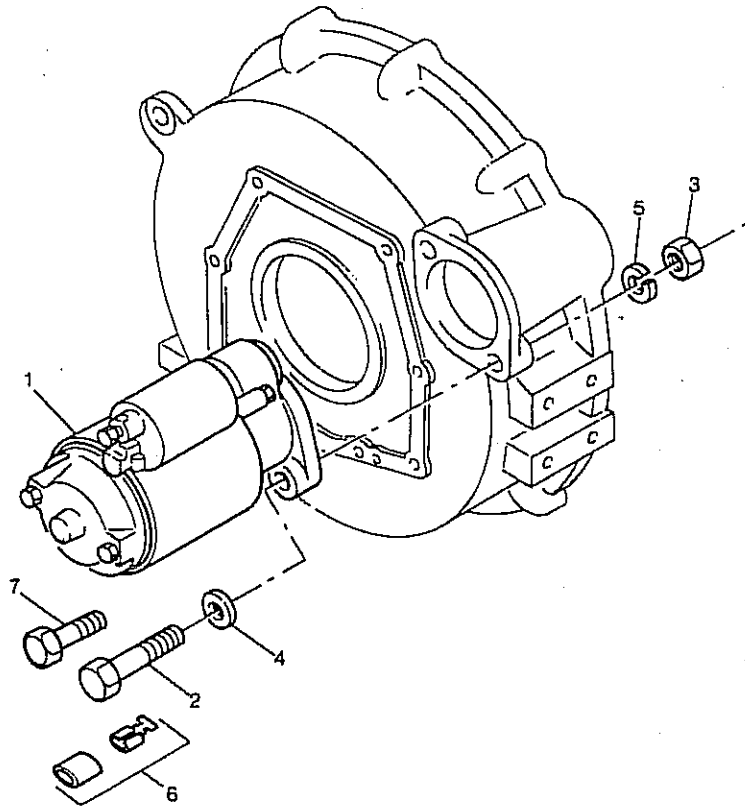

STARTER MOTOR
 DEMARREUR
 ANLASSER
 MOTORINO AVVIAMENTO
 ARRANCADOR

EDHK0611

PLATE A
 PLAQUE A
 PLATTE A
 PIASTRA A
 PLACA A

1	185086291	(A)	1	Startermotor	Demarreur Motorino avviam.	Anlasser Motor arranque
2	010101030		2	Screw	Vis Vite	Schraube Tornillo
3	020100010		2	Nut	Ecrou Dado	Mutter Tuerca
4	026100010		2	Washer	Rondelle Rondella	Unterlegscheibe Arandela
5	027100010		2	Washer	Rondelle Rondella	Unterlegscheibe Arandela

(A) SEE FOLLOWING PARTS LIST FOR SERVICE COMPONENTS
 VOIR CHAPITRE SUIVANT POUR DETAILS
 FUER SERVICETEILE S.NACHFOLGENDE E.T.LISTE
 VEDERE DI SEGUITO PER COMPONENTI SERVINILI
 VEASE LA LISTA DE PIEZAS QUE SIGUE PARA LOS COMPONENTES DE SERVICIO

K9223 EDHK-001-C

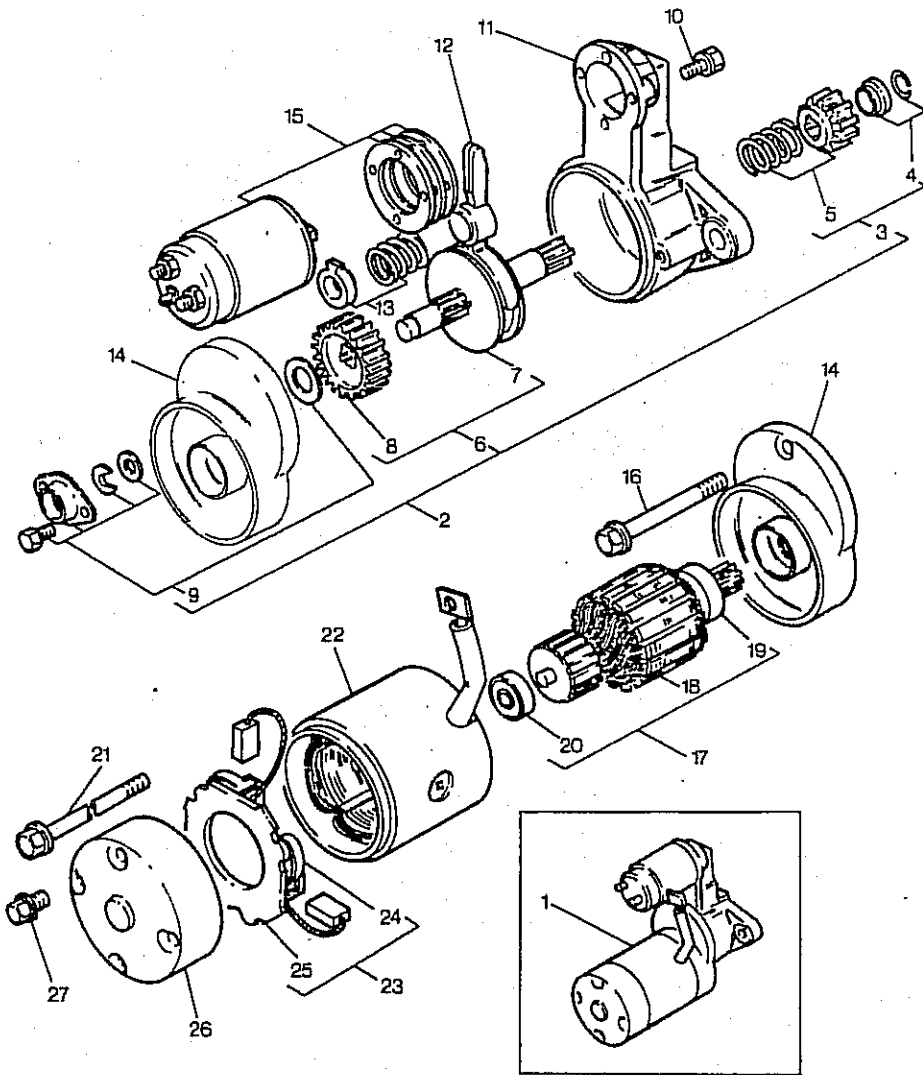

STARTER MOTOR
 DEMARREUR
 ANLASSER
 MOTORINO AVVIAMENTO
 ARRANCADOR

PLATE C
 PLAQUE C
 PLATTE C
 PIASTRA C
 PLACA C

EDHK0611

1	185086291		1	Startermotor	Demarreur Motorino avviam.	Anlasser Motor arranque
2	185866180	1	1	Shaft	Arbre Albero	Welle Arbol
3	185846406	2	1	Pinion	Pignon Pignone	Ritzel Pinon
4	185846327	3	1	Circlip	Segment d arret Anello d'arresto	Sicherungsring Circulito
5		3 → REF.3	1	Gear	Engrenage Ingranaggio	Zahnrad Engranaje
6	185846328	2	1	Gear	Engrenage Ingranaggio	Zahnrad Engranaje
7	185866130	6	1	Shaft	Arbre Albero	Welle Arbol
8	185846329	6	1	Gear	Engrenage Ingranaggio	Zahnrad Engranaje
9	185846330	2	1	Cover	Couvercle Coperchio	Deckel Cubierta
10	185846317	1	2	Screw	Vis Vite	Schraube Tornillo
11	185846467	1	1	Cover	Couvercle Coperchio	Deckel Cubierta
12	185846319	1	1	Lever	Levier Leva	Hebel Palanca
13	185846320	1	1	Spring	Ressort Molla	Feder Muelle
14	185846321	1	1	Bracket	Support fixation Supporto fissagg	Haltearm Soporte
15	185816120	1	1	Switch	Interrupteur Interruttore	Schalter Interruptor
16	185846322	1	1	Bolt	Boulon Bullone	Masch.schraube Perno
17	185846357	1	1	Armature	Induit Armatura	Induktionsanker Inducido
18		17 → REF.17	1	Armature	Induit Armatura	Induktionsanker Inducido
19	185846324	17	1	Bearing	Coussinet Cuscinetto	Lager Cojinete
20	185846325	17	1	Bearing	Coussinet Cuscinetto	Lager Cojinete
21	185846363	1	2	Bolt	Boulon Bullone	Masch.schraube Perno
22	185846364	1	1	Housing	Carter Carcassa	Gehaeuse Alojamiento
23	185846360	1	1	Brush	Balai Spazzola	Buerste Escobilla
24	185846361	23	4	Spring	Ressort Molla	Feder Muelle

K9223 EDHK-001-C

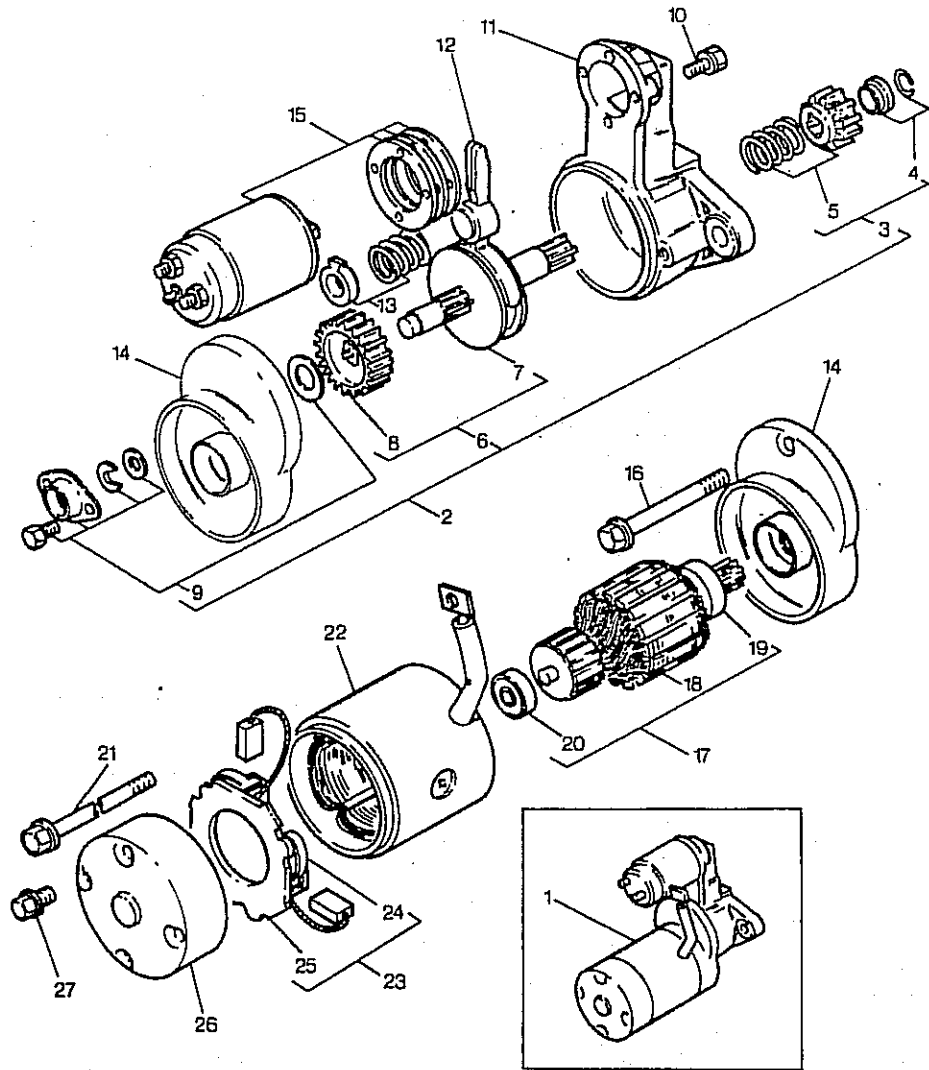

STARTER MOTOR
 DEMARREUR
 ANLASSER
 MOTORINO AVVIAMENTO
 ARRANCADOR

PLATE C
 PLAQUE C
 PLATTE C
 PIASTRA C
 PLACA C

EDHK0611

25		23 → REF.23	1	Holder	Piece support	Halter
26	185846362	1	1	Cover	Supporto di base	Sujetador
27	185846317	1	3	Screw	Couvercle	Deckel
					Coperchio	Cubierta
					Vis	Schraube
					Vite	Tornillo

K9231 GBHK-001-A

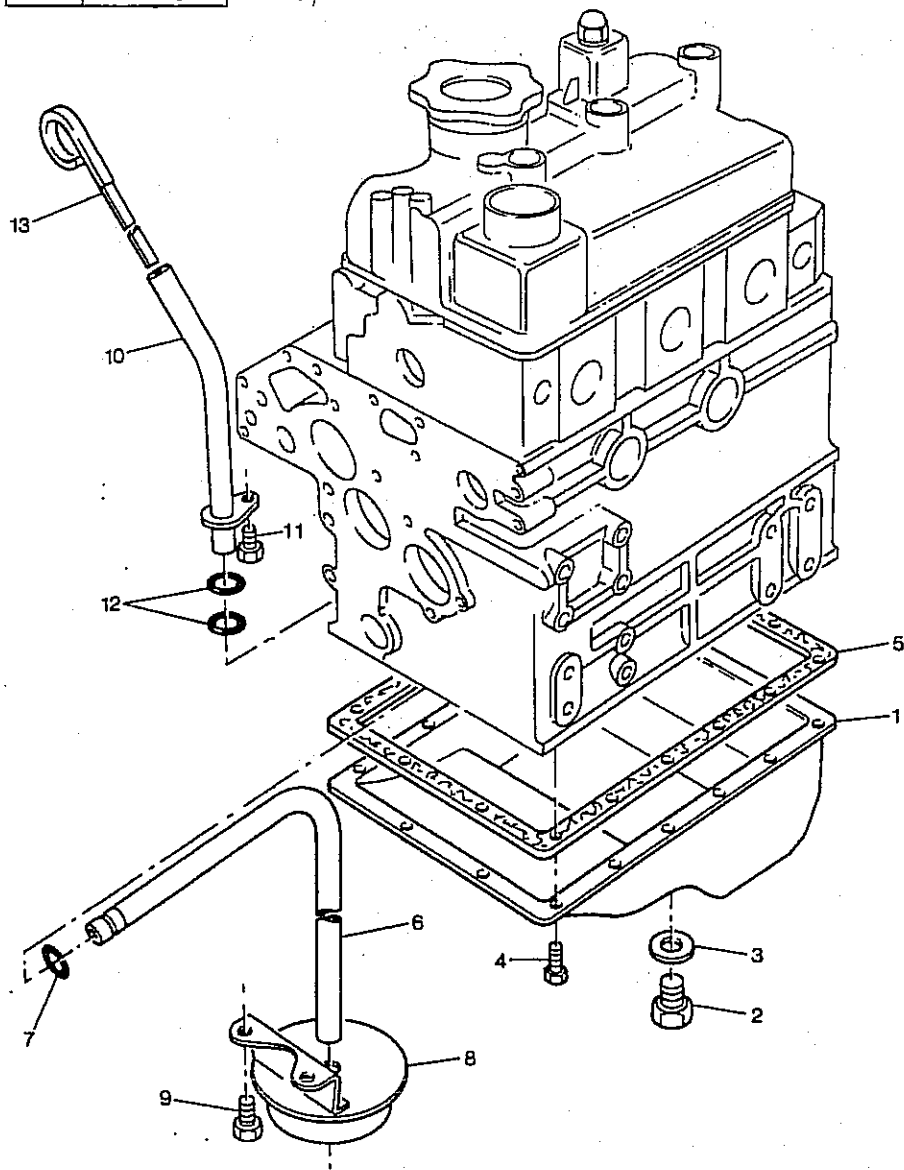

LUBRICATING OIL SUMP
 CARTER D'HUILE
 SCHMIERDELWANNE
 COPPA OLIO
 CARTER DEL ACEITE LUBRICANTE

GBHK1379

PLATE A
 PLAQUE A
 PLATTE A
 PIASTRA A
 PLACA A

1	110706880	1	Sump	Carter d huile Sottocoppa	Öelwanne Carter
2	010401212	1	Plug	Bouchon	Verschlostpfen
3	025100012	1	Washer	Rondelle Rondella	Tapon Unterlegscheibe Arandela
4	010109235	26	Screw	Vis Vite	Schraube Tornillo
5	110996560	1	Gasket	Joint Guarnizione	Dichtscheibe Empaquedatura
6	140986530	1	Pipe	Canalisation Tubo	Rohrleitung Cano
7	052109076	1	O ring	Joint torique Anello or	O-ring Junta torica
8	140406310	1	Strainer	Crepine Colino	Filtersieb Colador
9	011310612	2	Screw	Vis Vite	Schraube Tornillo
10	110756140	1	Gauge	Appareil indicat Misuratore	Messgeraet Aparat indicador
11	011300612	1	Bolt	Boulon Bullone	Masch.schraube Perno
12	052100100	2	O ring	Joint torique Anello or	O-ring Junta torica
13	198416320	1	Dipstick	Jauge Asta livello	Messtab Varilla aceite

K9251 HBHK-003-A

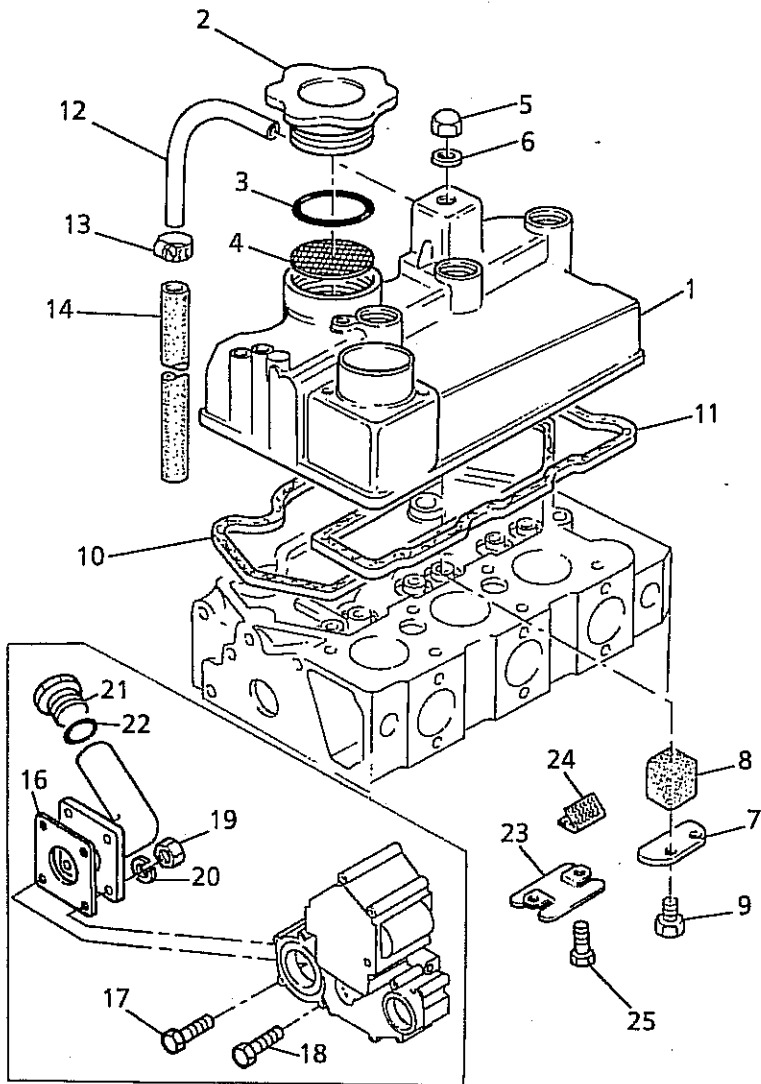

LUBRICATING OIL FILLER AND BREATHER
 REMPLISSEUR D'HUILE ET RENIFLARD
 DELEINFUELLSTUTZEN UND ENTLUEFTUNG
 TAPPO RIEMPIIMENTO E SFIATATOIO
 RENIFLARD Y LLENADO DEL ACEITE LUBRICANTE
 HBHK1389

PLATE A
 PLAQUE A
 PLATTE A
 PIASTRA A
 PLACA A

1	111026490	● 111216720	1	Cover	Couvercle Coperchio	Deckel Cubierta
2	198436010		1	Cap	Chapeau Cappello	Kappe Tapa
3	052100400		1	Seal	Bague etancheite Paraolio	Dichtring Reten
5	024500008		3	Nut	Ecrou Dado	Mutter Tuerca
6	198996060		3	Washer	Rondelle Rondella	Unterlegscheibe Arandela
10	052109064		1	Joint	Joint plat Giunto	Dichtung Junta
12	140986581	1	1	Pipe	Canalisation Tubo	Rohrleitung Cano
14	068109036		1	Hose	Durite Tubo flessibile	Schlauch Flexible
*	23	110666050	1	Plate	Plaque Piastra	Platte Plato
*	24	110666090	1	Gauze	Gaze Garza	Gaze Gasa
*	25	011300612	1	Bolt	Boulon Bullone	Masch.schraube Perno

K9271 JBHK-001-A

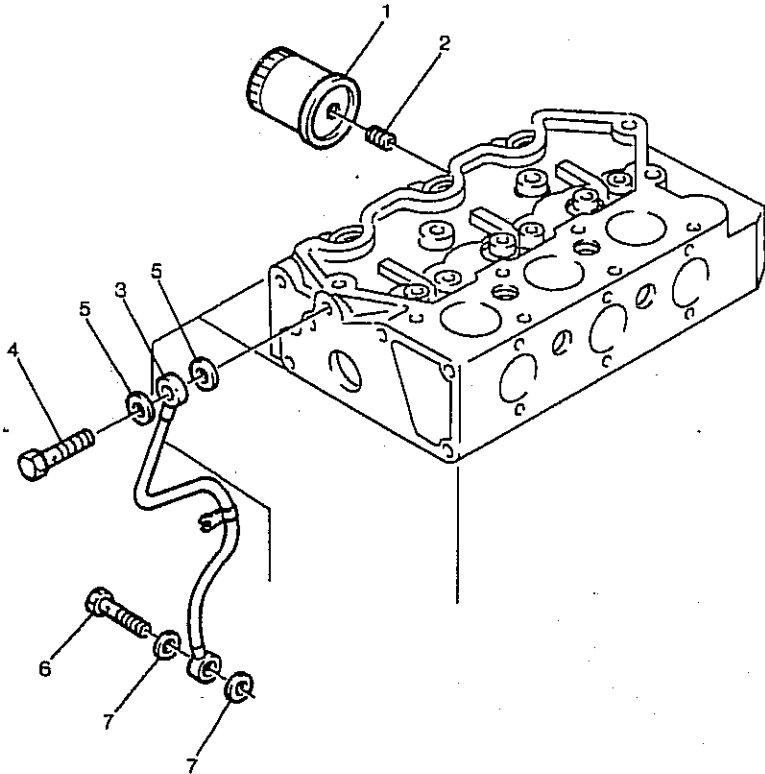

LUBRICATING OIL FILTER AND INTEGRAL OIL COOLER
 FILTRE A HUILE ET REFROIDISSEUR D'HUILE
 SCHMIEROELFILTER UND MOTORSEITIGER DELHUEHLER
 FILTRO OLIO E REFRIGERATORE INTEGRALE
 FILTRO Y ENGRIADOR INTEGRAL

PLATE A
 PLAQUE A
 PLATTE A
 PIASTRÀ A
 PLACA A

JBHK1071

1	140516130	1	Oil filter	Filtre huile Filtro olio	Oelfilter Filtro de aceite
2	140546020	1	Connection	Connexion Conessione	Verbindung Conexion
3	140606691	1	Pipe	Canalisation Tubo	Rohrleitung Cano
4	198486780	1	Bolt	Boulon Bullone	Masch.schraube Perno
5	198996060	2	Washer	Rondelle Rondella	Unterlegscheibe Arandela
6	198486780	1	Bolt	Boulon Bullone	Masch.schraube Perno
7	198996060	2	Washer	Rondelle Rondella	Unterlegscheibe Arandela

K9301 KBHK-002-A

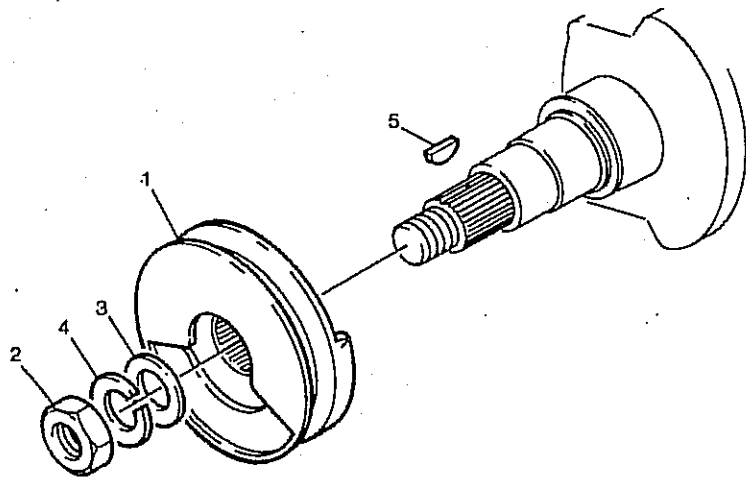

FRONT END DRIVE INPUT
PUISSANCE ABSORBEE A L'AVANT
KURBELWELLENGETRIEBE (VORNE)
TRASMISSIONE ANTERIORE ENTRATA
ENTRADA DEL MANDO DELANTERO

PLATE A
PLAQUE A
PLATTE A
PIASTRA A
PLACA A

KBHK0577

1	115396710	1	Pulley	Poulie Puleggia	Riemenscheibe Polea
2	020109086	1	Nut	Ecrou Dado	Mutter Tuerca
3	026100024	1	Washer	Rondelle Rondella	Unterlegscheibe Arandela
5	034100508	1	Key	Clavette Chiavetta	Passkeil Clave

K9322 LBHK -002- B

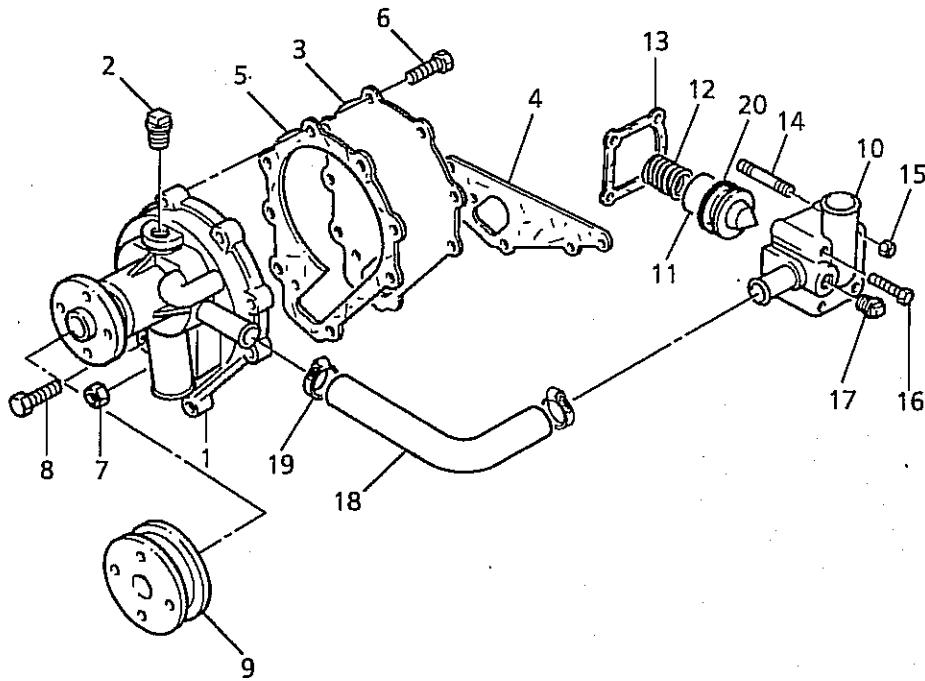

WATER PUMP, THERMOSTAT AND HEAT EXCHANGER
 POMPE A EAU ET THERMOSTAT
 WASSERPUMPE, THERMOSTAT UND WAERMETAUSCHER
 POMPA ACQUA, TERMOSTATO E SCAMBIATORE DI CALORE
 BOMBA DEL AGUA, TERMOSTATO CAMBIADOR DE TEMPERATURA
 LBHK1435

PLATE B
 PLAQUE B
 PLATTE B
 PIASTRA B
 PLACA B

1	145016870	1	Water pump	Pompe a eau Pompa acqua	Wasserpumpe Bomba de agua
2	064500030	1	Plug	Bouchon Tappo	Verschl.stopfen Tapon
3	145146300	1	Plate	Plaque Piastra	Platte Plato
4	145996370	1	Joint	Joint plat Giunto	Dichtung Junta
5	145996450	1	Gasket	Joint Guarnizione	Dichtscheibe Empaquetadura
6	015300614	5	Screw	Vis Vite	Schraube Tornillo
7	023100006	1	Nut	Ecrou Dado	Mutter Tuerca
8	011300635	6	Screw	Vis Vite	Schraube Tornillo
9	145336620	1	Pulley	Poulie Puleggia	Riemenscheibe Polea
10	145216151	1	Housing	Carter Carcassa	Gehaeuse Alojamiento
11	145206021	1	Thermostat	Thermostat Termostato	Thermostat Termostato
12	198216790	1	Spring	Ressort Molla	Feder Muella
13	145996360	1	Gasket	Joint Guarnizione	Dichtscheibe Empaquetadura
14	012100645	2	Stud	Goujon Prigioniero	Stehbolzen Esparrago
15	023100006	2	Nut	Ecrou Dado	Mutter Tuerca
16	011300645	2	Screw	Vis Vite	Schraube Tornillo
17	064500030	1	Plug	Bouchon Tappo	Verschl.stopfen Tapon
* 18	145536050	1	Hose	Durite Tubo flessibile	Schlauch Flexible
19	067100022	2	Clip	Circlip Fermaglio	Schelle Crapa reten
* 20	145996590 (A)	1	Seal	Bague etancheite Paraolio	Dichtring Reten

*(A) USED ONLY WITH 145206021
 EMPLOYEE SEULEMENT AVEC 145206021
 NUR FUER 145206021
 USATO SOLO CON 145206021
 EMPLEADA SOLAMENTE CON 145206021

K9350 MDHK-003-A

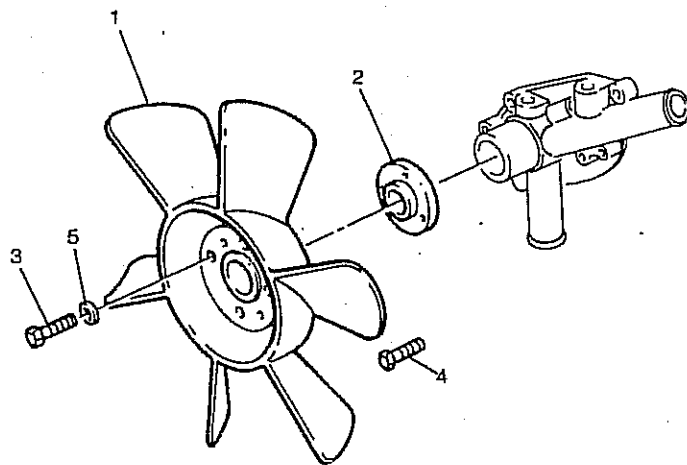

FAN AND EXTENSION
VENTILATEUR ET ENTRETOISE
LUFTER UND ZWISCHENSTUECK
VENTOLA E DISTANZIALE
VENTILADOR Y PROLONGACION

MDHK0817

PLATE A
PLAQUE A
PLATTE A
PIASTRA A
PLACA A

1	145306491	1	Fan	Ventilateur Ventola	Luefter Ventilador
2	145386390	1	Plate	Plaque Piastra	Platte 915047 Plato
3	011310616	4	Screw	Vis Vite	Schraube 91504 Tornillo

K9358 NDHK-001-C

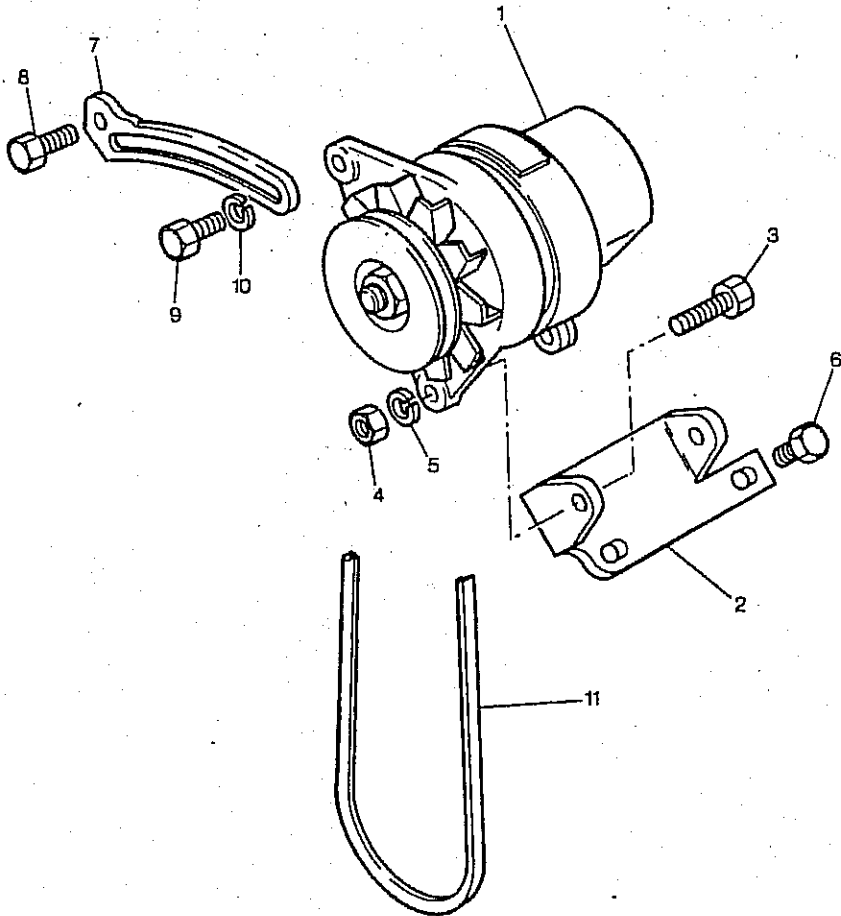

ALTERNATOR AND GENERATOR
 ALTERNATEUR ET DYNAMO
 DREHSTROM-WECHSELSTROM-LICHTMASCHINE
 ALTERNATORE E GENERATORE
 ALTERNADOR Y DINAMO

PLATE C
 PLAQUE C
 PLATTE C
 PIASTRA C
 PLACA C

NDHK1760

* 1	185046320 (A) 185046200	1	Alternator	Alternateur Alternatore	Lichtm.drehstrom Alternador
2	185976200	1	Bracket	Support fixation Supporto fissagg	Haltearm Soporte
3	010101035	2	Screw	Vis Vite	Schraube Tornillo
4	020100010	2	Nut	Ecrou Dado	Mutter Tuerca
5	027100010	2	Washer	Rondelle Rondella	Unterlegscheibe Arandela
6	011300816	3	Screw	Vis Vite	Schraube Tornillo
7	185726340	1	Plate	Plaque Piastra	Platte Plato
8	011300820	1	Screw	Vis Vite	Schraube Tornillo
9	011300820	1	Screw	Vis Vite	Schraube Tornillo
10	026200008	1	Washer	Rondelle Rondella	Unterlegscheibe Arandela
11	080109061 080109024	1	Belt	Courroie Cinghia	Riemen Correa

(A) SEE FOLLOWING PARTS LIST FOR SERVICE COMPONENTS
 VOIR CHAPITRE SUIVANT POUR DETAILS
 FUER SERVICETEILE S.NACHFOLGENDE E.T.LISTE
 VEDERE DI SEGUITO PER COMPONENTI SERVINILI
 VEASE LA LISTA DE PIEZAS QUE SIGUE PARA LOS COMPONENTES DE SERVICIO

K 9359 NDHK-001-D

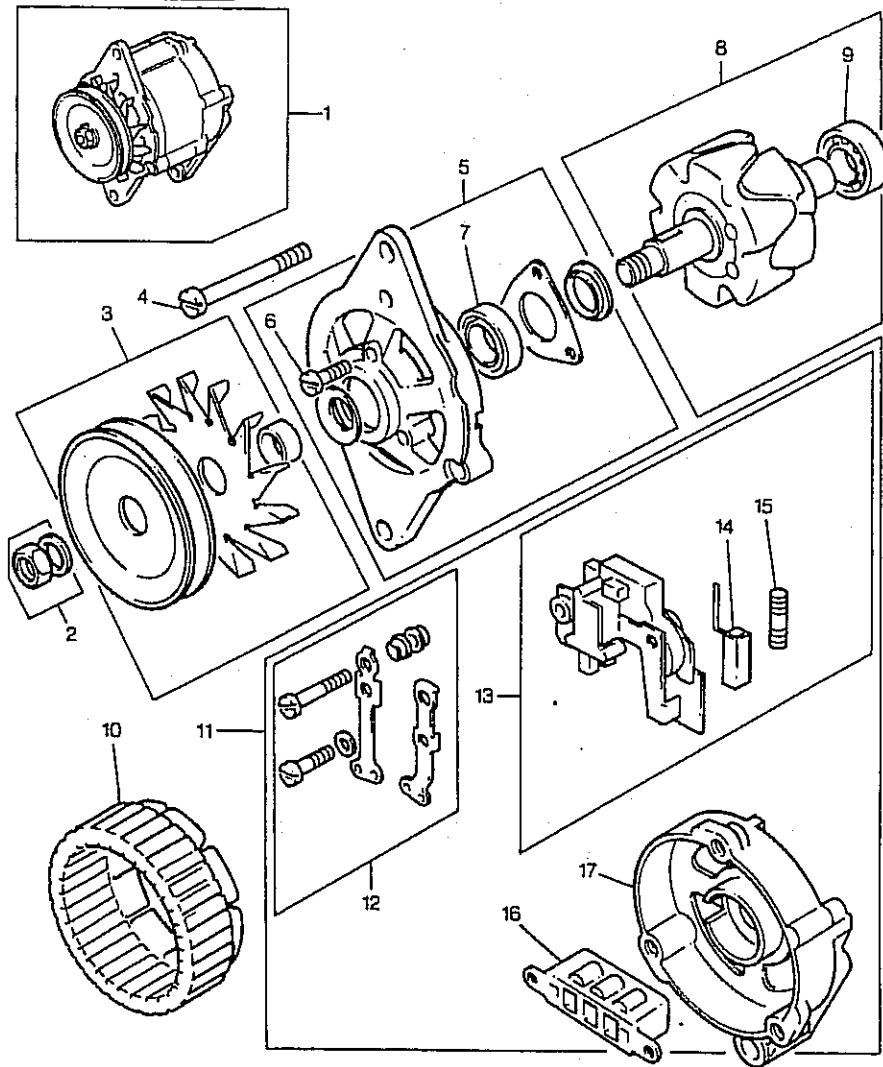

ALTERNATOR AND GENERATOR
 ALTERNATEUR ET DYNAMO
 DREHSTROM-WECHSELSTROM-LICHTMASCHINE
 ALTERNATORE E GENERATORE
 ALTERNADOR Y DINAMO

NDHK1760

PLATE D
 PLAQUE D
 PLATTE D
 PIASTRA D
 PLACA D

* 1	185046201	● 185046200	1	Alternator	Alternateur Alternatore	Lichtm.drehstrom Alternador
* 2	185446157	1	1	Nut	Ecrou Dado	Mutter Tuerca
3	185436120	1	1	Pulley	Poulie Puleggia	Riemenscheibe Polea
4	185446158	1	3	Screw	Vis Vite	Schraube Tornillo
5	185426130	1	1	Cover	Couvercle Coperchio	Deckel Cubierta
6	185446182	5	3	Screw	Vis Vite	Schraube Tornillo
* 7	185446246	5 ● 185446214	1	Bearing	Coussinet Cuscinetto	Lager Cojinete
* 8	185336252	1 ● 185446183	1	Rotor	Rotor Rotore	Rotor Rotor
* 9	185446251	8 ● 185446215	1	Bearing	Coussinet Cuscinetto	Lager Cojinete
10	185446162	1	1	Stator	Stator Statore	Stator Estator
11	185446140	1	1	Cover	Couvercle Coperchio	Deckel Cubierta
12	185446188	11	1	Terminal	Boite a relais Terminale	Anschlussklemme Terminal
13	185446187	11	1	Regulator	Regulateur Regolatore	Regler Regulador
14	185416300	13	1	Brush	Balai Spazzola	Buerste Escobilla
15	185446165	13	1	Spring	Ressort Molla	Feder Muelle
16	185446216	11	1	Rectifier	Redresseur Raddrizzatore	Gleichrichter Rectificador
17		11 → REF.11	1	Cover	Couvercle Coperchio	Deckel Cubierta

K9405 QDHK-002-A

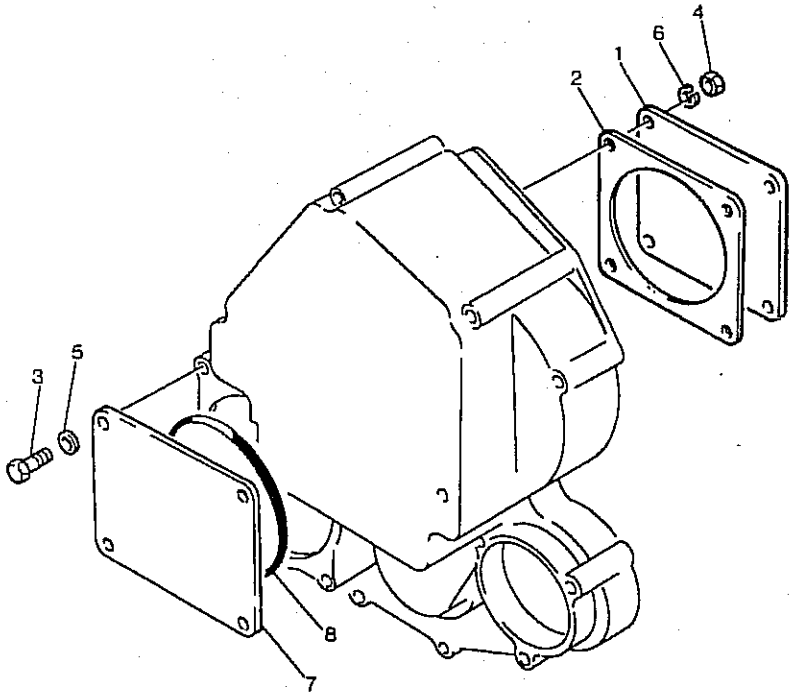

GEAR DRIVE AUXILIARY DRIVE OPTIONS
 ENTRAINEMENT PAR PIGNON DES EQUIPEMENTS AUXILIAIRES
 ZAHNRADANGETRIEBENE NEBENAGGREGATE-WAHLWEISE
 TRASMISSIONE AUSILIARIA A RICHIESTA
 EQUIPO OPCIONAL DE MANDO AUXILIAR ACCIONADO ENGRANAJES
 QDHK0903

PLATE A
 PLAQUE A
 PLATTE A
 PIASTRA A
 PLACA A

● QDHK0856

1	165206010	1	Plate	Plaque Piastra	Platte Plato
2	165996110	1	Joint	Joint plat Giunto.	Dichtung Junta
3	011300860	4	Screw	Vis Vite	Schraube Tornillo
4	023100008	4	Nut	Ecrou Dado	Mutter Tuerca
7	165206010	1	Plate	Plaque Piastra	Platte Plato
8	052300600	1	O ring	Joint torique Anello or	O-ring Junta torica

K9460 TBHK-001-A

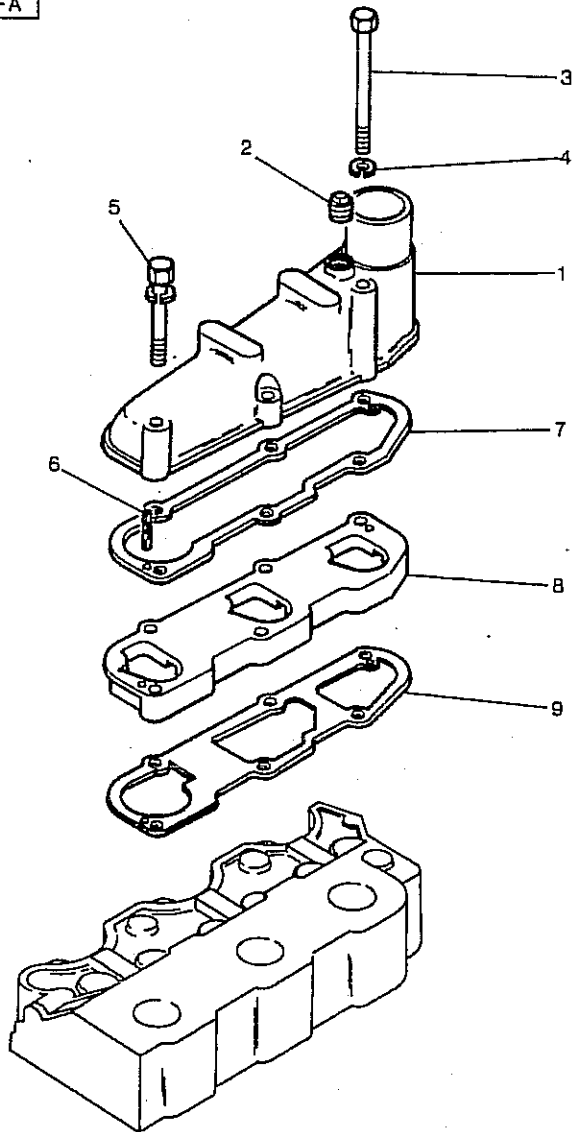

INDUCTION MANIFOLD
 COLLECTEUR D'ADMISSION
 ANSAUGKRUEMMER
 COLLETTORE ASPIRAZIONE
 MULTIPLE DE ADMISION

TBHK0555

PLATE A
 PLAQUE A
 PLATTE A
 PIASTRA A
 PLACA A

1	135596650		1	Ind.manifold	Collecteur adm Collettore asp.	Ansaugkrueimmer Multiple admision
2	064500010		1	Plug	Bouchon Tappo	Verschl.stopfen Tapon
3	010109119		2	Bolt	Boulon Bullone	Masch.schraube Perno
4	027100006		2	Washer	Rondelle Rondella	Unterlegscheibe Arandela
5	011300660		4	Screw	Vis Vite	Schraube Tornillo
6	030300414		2	Pin	Goupille Perno	Bolzen Pasador
7	135996451		1	Gasket	Joint Guarnizione	Dichtscheibe Empaquedatura
8	135597040	● 135596501	1	Spacer	Entretoise Distanziale	Abstandstueck Pieza distancia
9	135996680	● 135996501 ● 135996471	1	Joint	Joint plat Giunto	Dichtung Junta

K9480|UBHK-002-A

EXHAUST MANIFOLD
 COLLECTEUR ECHAPPEMENT
 AUSPUFFKRUEMMER
 COLLETTORE DI SCARICO
 MULTIPLE DE ESCAPE

PLATE A
 PLAQUE A
 PLATTE A
 PIASTRA A
 PLACA A

UBHK0347

7	135616600	1	Exhaust manifold	Collecteur ech	Auspuffkrummer
				Collettore scar.	Colector escape
8	135996590	1	Joint	Joint plat	Dichtung
				Giunto	Junta
9	012110625	2	Stud	Goujon	Stehbolzen
				Prigioniero	Esparrago
10	023100006	2	Nut	Ecrou	Mutter
				Dado	Tuerca
11	011310625	4	Screw	Vis	Schraube
				Vite	Tornillo

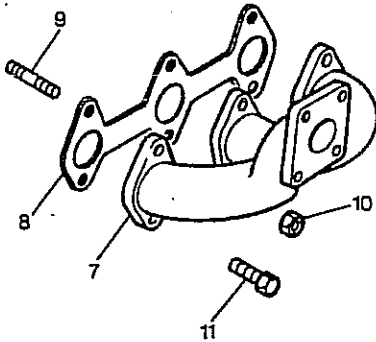
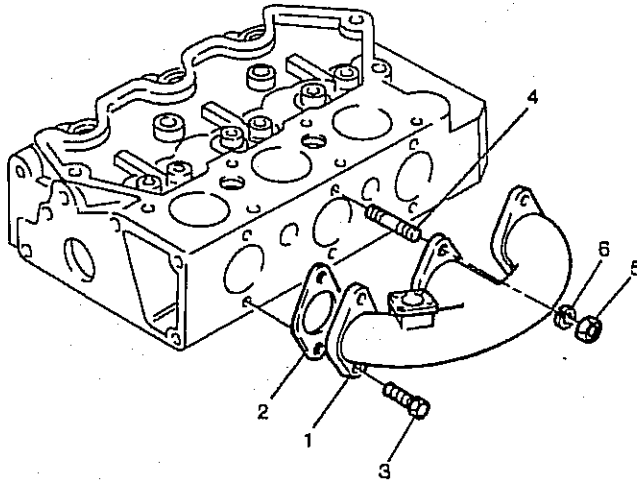

K9500 VBHK-002-A

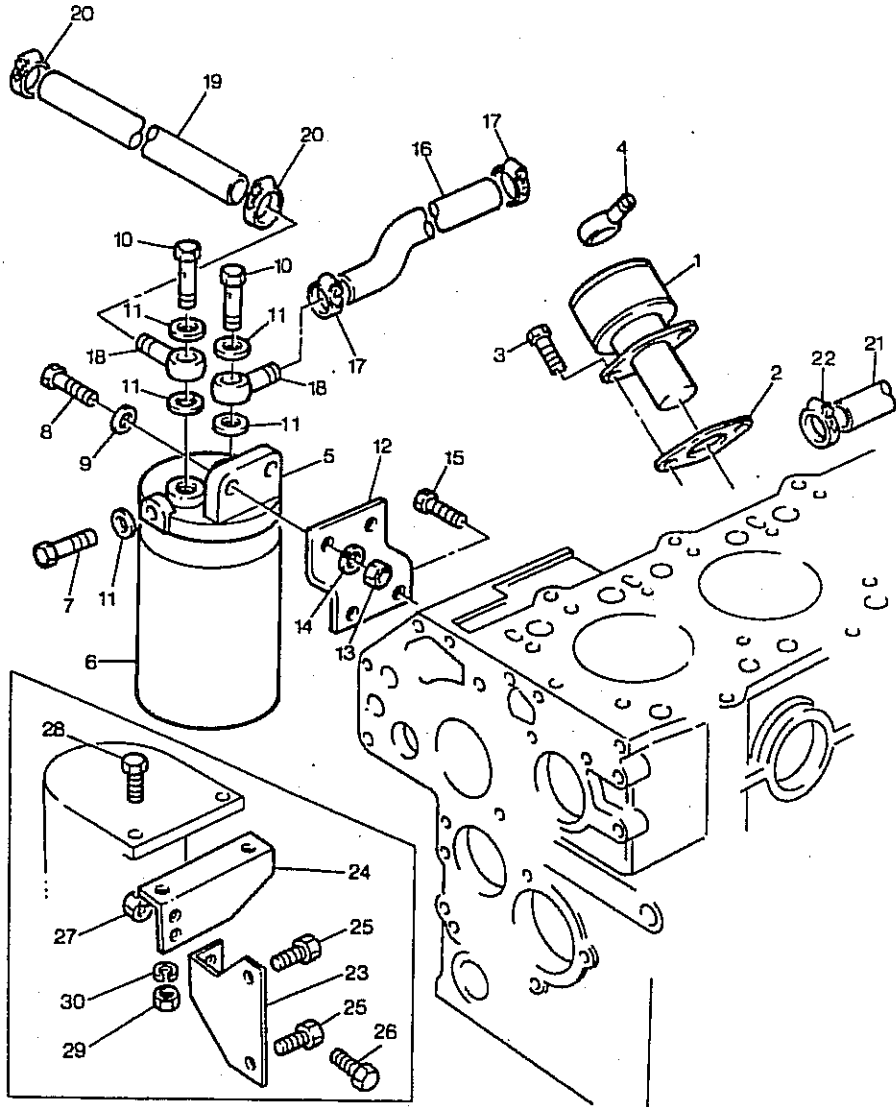

LOW PRESSURE FUEL SYSTEM
 CIRCUIT CARBURANT BASSE PRESSION
 KRAFTSTOFF-NIEDERDRUCKANLAGE
 SISTEMA NAFTA A BASSA PRESSIONE
 SISTEMA DE COMBUSTIBLE A BAJA PRESION-

VBHK1393

PLATE A
 PLAQUE A
 PLATTE A
 PIASTRA A
 PLACA A

1	130506140	(A)	1	Lift pump	Pompe relevage Pompa sollevamen	Foerderpumpe Bomba elevacion
2	130996070		1	Joint	Joint plat Giunto	Dichtung Junta
3	011300616		2	Screw	Vis Vite	Schraube Tornillo
4	198486840		2	Connection	Connexion Connessione	Verbindung Conexion

(A) SEE FOLLOWING PARTS LIST FOR SERVICE COMPONENTS
 VOIR CHAPITRE SUIVANT POUR DETAILS
 FUER SERVICE TEILE S.NACHFOLGENDE E.T.LISTE
 VEDERE DI SEGUITO PER COMPONENTI SERVINILI
 VEASE LA LISTA DE PIEZAS QUE SIGUE PARA LOS COMPONENTES DE SERVICIO

K9501 VBHK-001-B

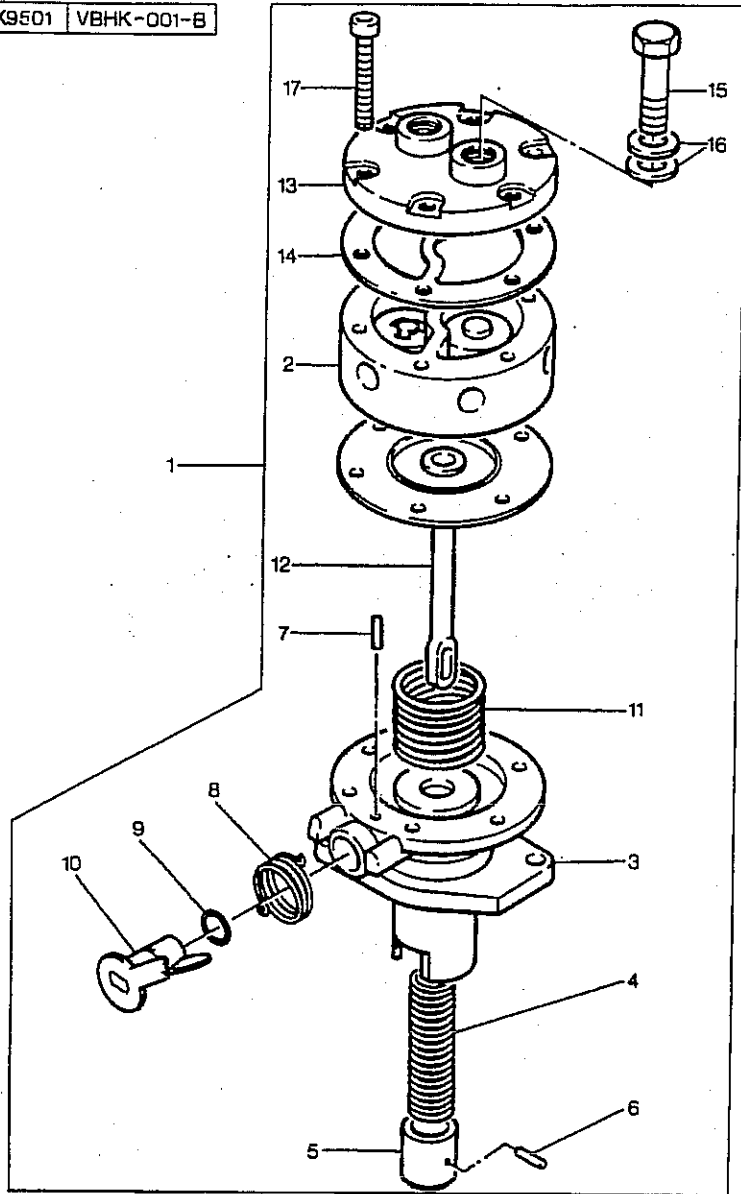

LOW PRESSURE FUEL SYSTEM
CIRCUIT CARBURANT BASSE PRESSION
KRAFTSTOFF-NIEDERDRUCKANLAGE
SISTEMA NAFTA A BASSA PRESSIONE
SISTEMA DE COMBUSTIBLE A BAJA PRESION

VBHK1393

PLATE B
PLAQUE B
PLATTE B
PIASTRA B
PLACA B

1	130506140	1	Lift pump	Pompe relevage Pompa sollevamen	Foerderpumpe Bomba elevacion
2	1	REF.1	Body	Corps Corpo	Koerper Cuerpo
3	130516080	1	Body	Corps Corpo	Koerper Cuerpo
4	130516081	1	Spring	Ressort Molla	Feder Muella
5	130516082	1	Plunger	Plongeur Stantuffo	Tauchkolben Embolo
6	130516085	1	Pin	Goupille Perno	Bolzen Pasador
7	130516088	1	Pin	Goupille Perno	Bolzen Pasador
8	130516083	1	Spring	Ressort Molla	Feder Muella
9	131226180	1	O ring	Joint torique Anello or	O-ring Junta torica
10	130516086	1	Lever	Levier Leva	Hebel Palanca
11	130516087	1	Spring	Ressort Molla	Feder Muella
12	130516084	1	Diaphragm	Membrane Diaframma	Membran Diafragma
13	130516090	1	Cap	Chapeau Cappello	Kappe Tapa
14	130516089	1	Gasket	Joint Guarnizione	Dichtscheibe Empaquedatura
15	130516092	2	Bolt	Bouion Bullone	Masch.schraube Perno
16	130516069	4	Washer	Rondelle Rondella	Unterlegscheibe Arandela
17	130516091	6	Screw	Vis Vite	Schraube Tornillo

K9520 WDHK-002-A

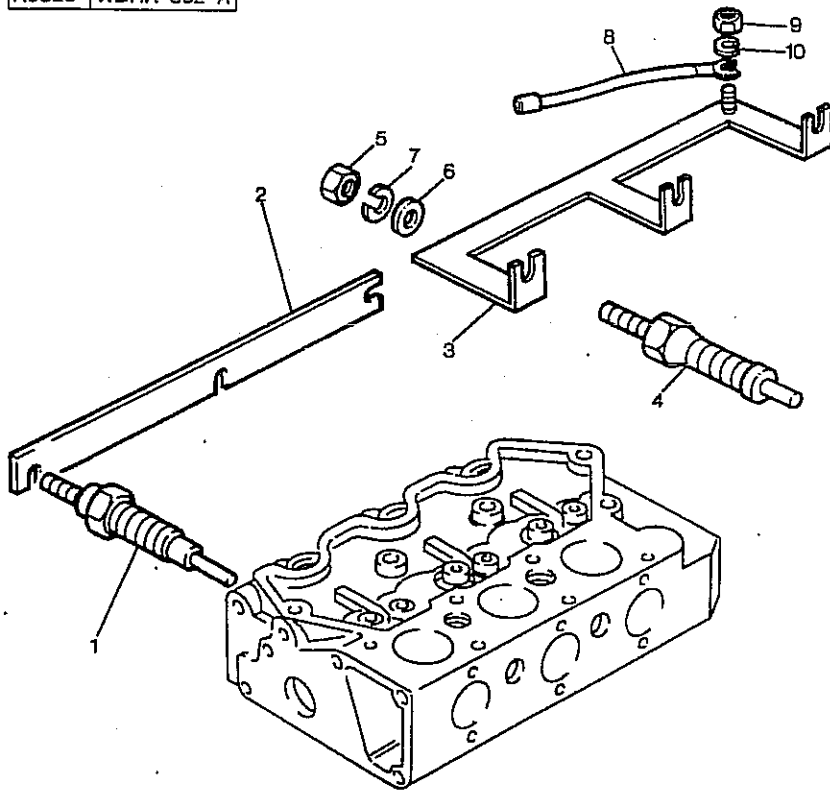

COLD START SYSTEM
 DIPOSITIF DEPART A FROID
 KALTSTARTANLAGE
 AVVIAMENTO A FREDDO
 SISTEMA DE ARRANQUE EN TIEMPO FRIO

WDHK0195

PLATE A
 PLAQUE A
 PLATTE A
 PIASTRA A
 PLACA A

3	185376140	1	Connector	Borne Morsetto	Doppelnippel Conector
4	185386060	3	Heater	Chauffage Riscaldatore	Heizung Calentador
5	4 REF.4	1	Nut	Ecrou Dado	Mutter Tuerca
6	4 REF.4	1	Washer	Rondelle Rondella	Unterlegscheibe Arandela
7	4 REF.NO.4	1	Washer	Rondelle Rondella	Unterlegscheibe Arandela
8	185606170	1	Cable	Cable Cavo	Kabel Cable
9	020100004	1	Nut	Ecrou Dado	Mutter Tuerca
10	027100004	1	Washer	Rondelle Rondella	Unterlegscheibe Arandela

K9530 XBHK-001-A

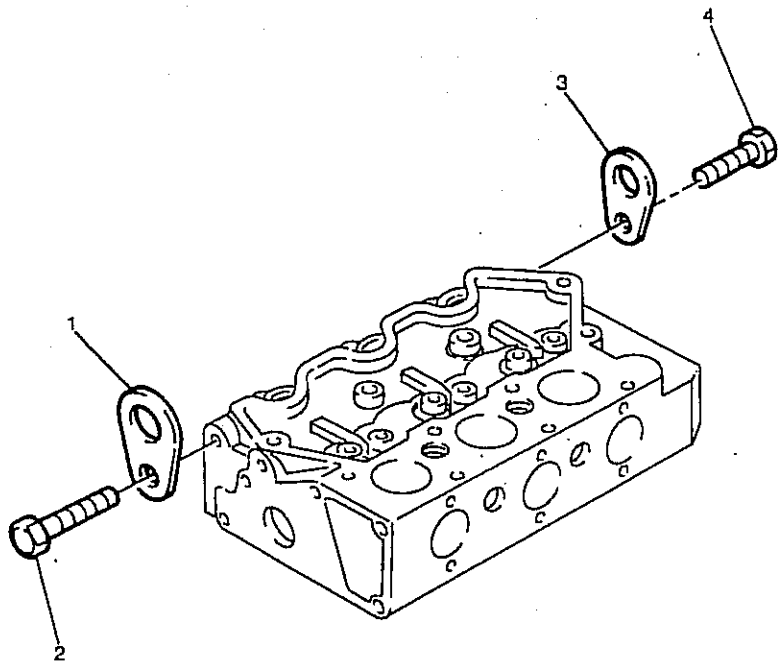

ENGINE LIFTING
LEVAGE MOTEUR
MOTORHEBEOESEN
SOLLEVAMENTO MOTORE
PLACA LEVANTADORAS DEL MOTOR

XBHK0308

PLATE A
PLAQUE A
PLATTE A
PIASTRA A
PLACA A

1	195816200	1	Plate	Plaque Piastra	Platte Plato
2	011310816	1	Screw	Vis Vite	Schraube Tornillo
3	195816200	1	Plate	Plaque Piastra	Platte Plato
4	011310816	1	Screw	Vis Vite	Schraube Tornillo

K9540 ZAHK-003-A

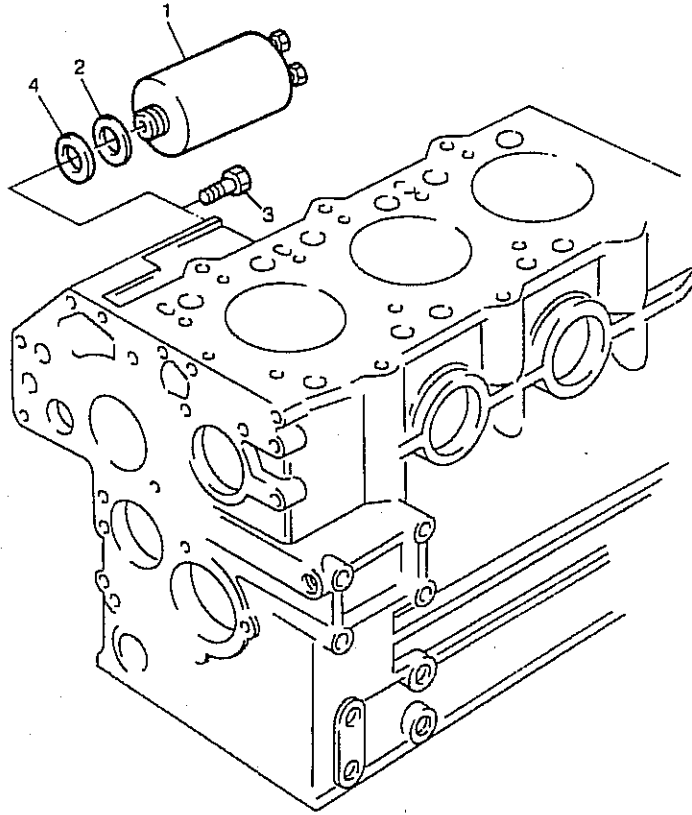

THROTTLE AND STOP CONTROLS
CONTROLE ACCELERATION ET STOP
GAS-UND ABSTELLHEBERL
COMANDO AVVIAMENTO ED ARRESTO
MANDOS DEL ACELERADOR Y PARADA

ZAHK0519

PLATE A
PLAQUE A
PLATTE A
PIASTRA A
PLACA A

1	185206082	185206081	1	Solenoid	Solenoide Solenoide	Magnetspule Solenoide
2	025100016		1	Washer	Rondelle Rondella	Unterlegscheibe Arandela

K9600 ZJHK-001-A

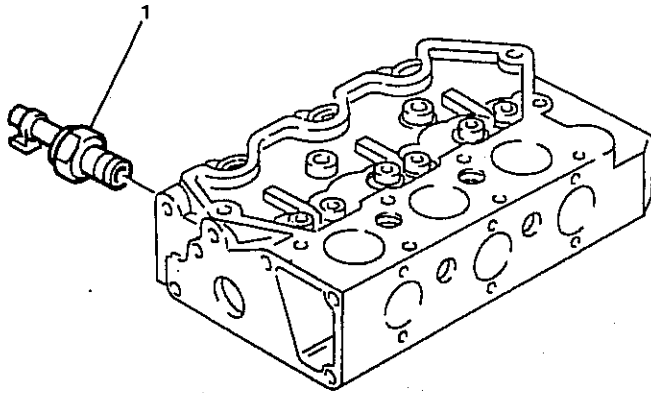

LUB. OIL PRESSURE SWITCH AND GAUGE
MANO. CONTACT PRESSION D'HUILE ET MANOMETRE
OELDRUCKSCHALTER UND OELDRUCKMANOMETER
MANO. E INTERRUPTORE PRESSIONE OLIO
TRANSMISOR E INDICADOR DE LA PRESION DE ACEITE LUB.
ZJHK0404

PLATE A
PLAQUE A
PLATTE A
PIASTRA A
PLACA A

1	185246060	1	Switch	Interrupteur Interruttore	Schalter Interruptor
---	-----------	---	--------	------------------------------	-------------------------

K9620 ZLHK-002-A

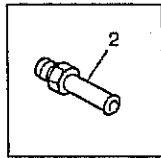
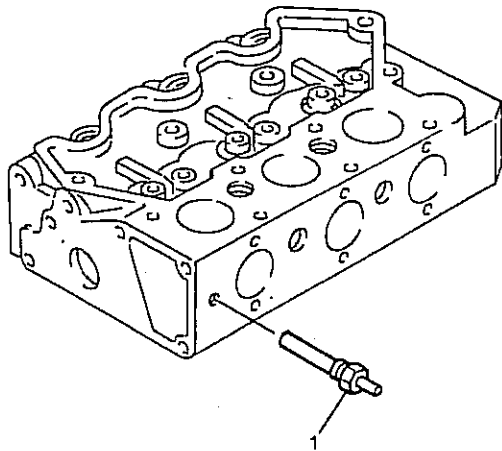

TEMPERATURE GAUGE AND SENDER
MANOMETRE TEMPERATURE TRANSMETTEUR
TEMPERATURANZEIGER UND-GEBER
BULBO E MANOMETRO TEMPERATURA
INDICADOR Y TRANSMISOR DE TEMPERATURA

ZLHK0180

PLATE A
PLAQUE A
PLATTE A
PIASTRA A
PLACA A

1	385720230	●	385720101	1	Sender	Emetteur Emittente	Geber Emisor
---	-----------	---	-----------	---	--------	-----------------------	-----------------

K9650 ZQHK-001-A

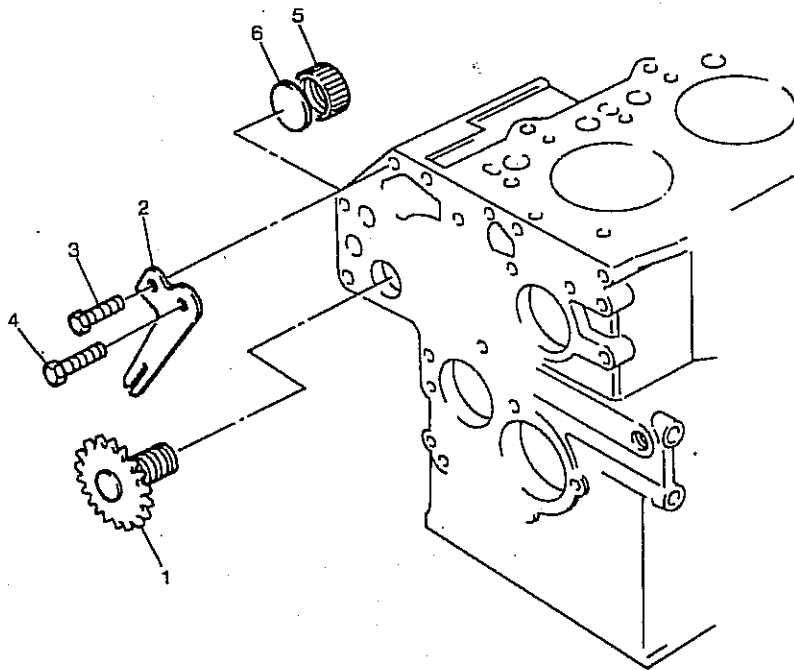

TACHOMETER AND HOUR RECORDER
 COMPTE-TOURS ET COMPTEUR D'HEURES
 TACHOMETER UND STUNDENZAehler
 TACHIMETRO E CONTAORE
 TAQUIMETRO Y CONTADOR DE HORAS

PLATE A
 PLAQUE A
 PLATTE A
 PIASTRA A
 PLACA A

ZQHK0529

1	120076070	1	Shaft	Arbre Albero	Welle Arbol
2	199566651	1	Plate	Plaque Piastra	Platte Plato
3	011310612	2	Screw	Vis Vite	Schraube Tornillo
5	199376230	1	Cap	Chapeau Cappello	Kappe Tapa
6	120996060	1	Seal	Bague etancheite Paraolio	Dichtring Reten

K9700 ZZHK-002-A

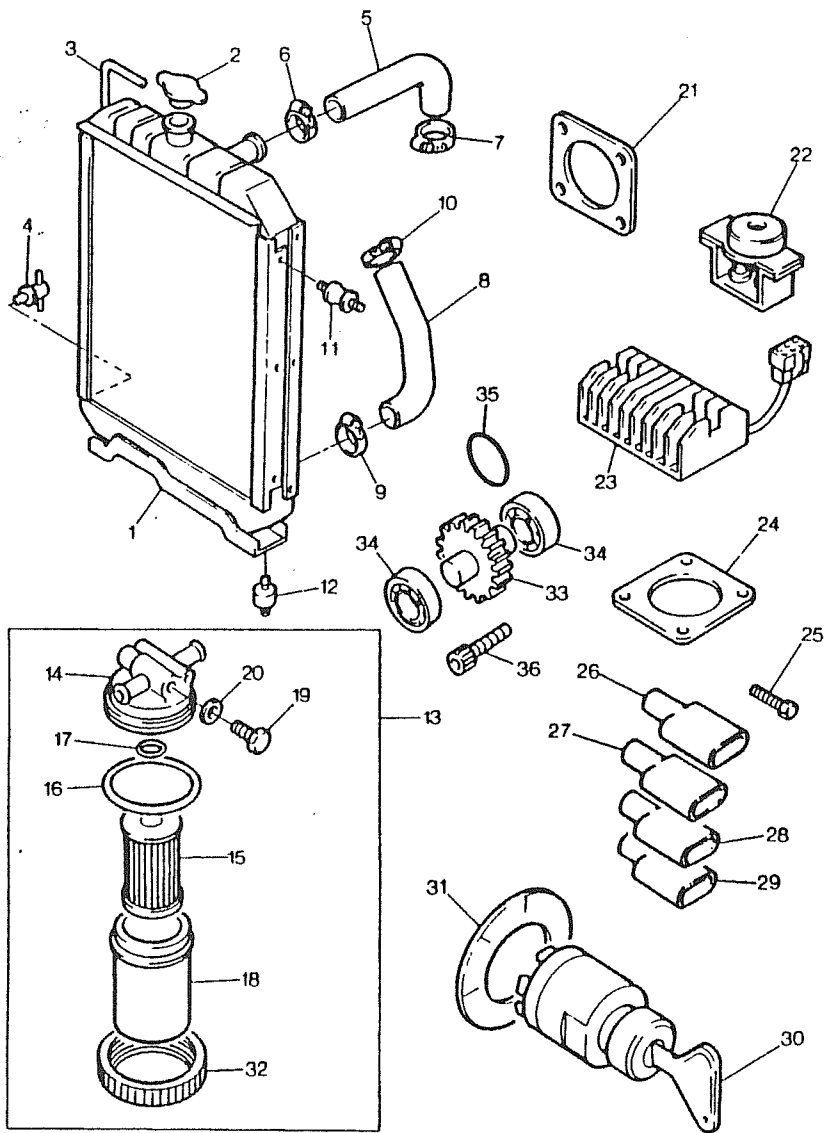

APPLICATION MISCELLANEOUS AND AUXILIARIES
 APPLICAZIONI DIVERSE ET AUXILIARES
 GERAETEZUBEHOER UND NEBENAGGREGATE
 APPLICAZIONI VARIE
 EQUIPO MISCELANEO Y AUXILIAR

PLATE A
 PLAQUE A
 PLATTE A
 PIASTRA A
 PLACA A

ZZHK0386

13	360700031	1	Filter	Filtre Filtro	Filter Filtro
14	13 ➔ REF.13	1	Head	Tete Testa	Kopf Culata
15	360720020 13	1	Element	Element Elemento	Element Elemento
16	052100400 13	1	Seal	Bague etancheite Paraolio	Dichtring Reten
17	052100100 13	1	O ring	Joint torique Anello or	O-ring Junta torica
18	360710011 13	2	Container	Cuve Contentore	Behaelter Contenedor
19	360740070 13	2	Plug	Bouchon Tappo	Verschl.stopfen Tapon
20	360740080 13	2	Washer	Rondelle Rondella	Unterlegscheibe Arandela
21	314990012	1	Joint	Joint plat Giunto	Dichtung Junta
24	314120070	1	Flange	Flasque Flangia	Flansch Pletina
25	011310825	4	Screw	Vis Vite	Schraube Tornillo
26	385620200	2	Connection	Connexion Connessione	Verbindung Conexion
27	385620220	1	Connector	Borne Morsetto	Doppelnippel Conector
28	385620230	1	Connector	Borne Morsetto	Doppelnippel Conector
29	385620270	1	Connection	Connexion Connessione	Verbindung Conexion
29	385620290	2	Connector	Borne Morsetto	Doppelnippel Conector
32	360740010 13	1	Ring	Anneau Anello	Ring Aro
33	340460130	1	Gear	Engrenage Ingranaggio	Zahnrad Engranaje
34	040106004	2	Bearing	Coussinet Cuscinetto	Lager Cojinete
35	052300700	1	O ring	Joint torique Anello or	O-ring Junta torica
36	011300860	1	Screw	Vis Vite	Schraube Tornillo

K9723 SGBK-001-A

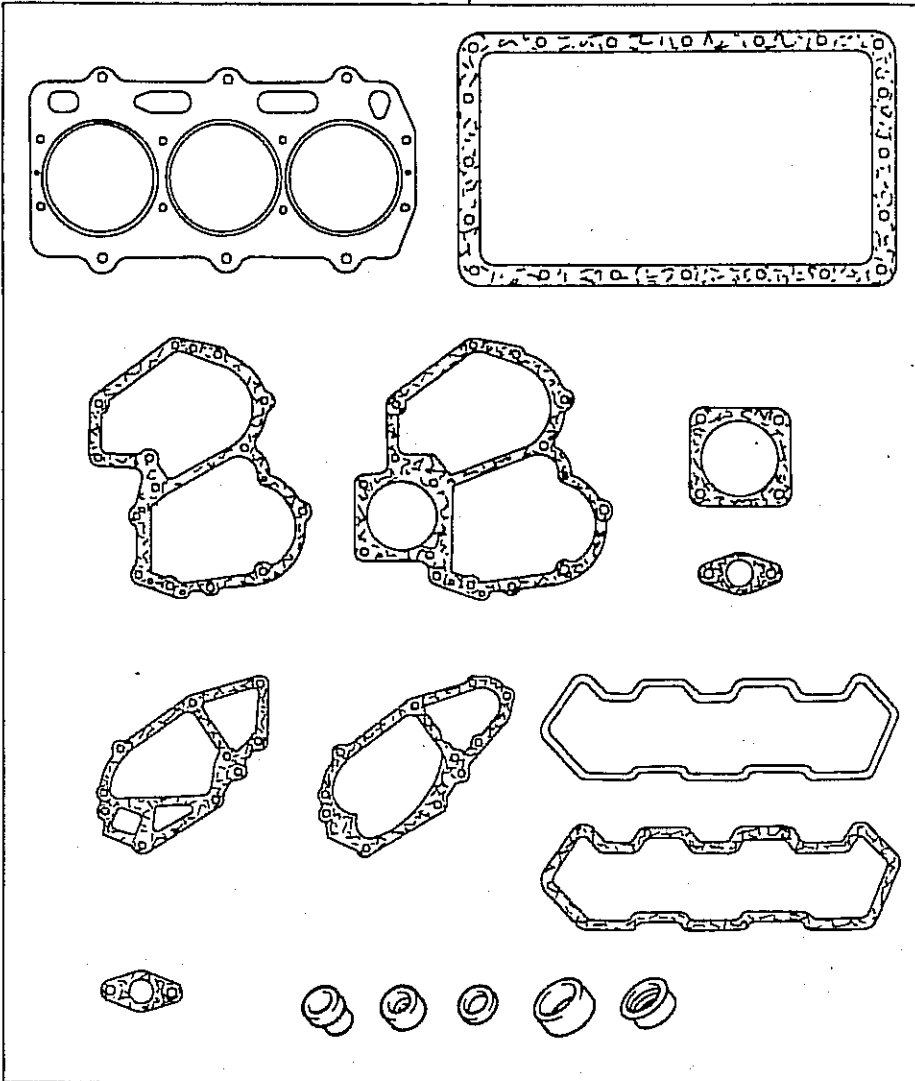

JOINTS AND GASKETS - COMPLETE SERVICE KIT
JEU DE JOINTS COMPLET
DICHRINGE UND DICHTUNGEN KOMPL.REP.-SATZ
SERLE COMPLETA GUARNIZIONI
JUNTAS Y EMPAQUETADURAS.JUEGO COMPLETO DE SERVICIO
SGBK0012

PLATE A
PLANCHE A
SEITE A
TAVOLA A
ILUSTRACION

1	195906640	X	Kit,joint/gasket	Jeu de joints Kit guarn/giunto	Dichtungs-satz Jgo.juntas/empac
---	-----------	---	------------------	-----------------------------------	------------------------------------

NUMERICAL INDEX

1	012110625	33	052100120	8	120116100	8	131296408	16	165206010	31
3	015300614	27	052100150	13	120166270	6	131296530	16	165296130	2
4	020100004	36	052100400	24	120176280	6	131296531	16	165996110	31
5	020100010	20		43	120186080	6	131296532	16	165996351	9
9		29	052109064	24	120216040	6	131296645	16	165996361	9
11	020109076	8	052109065	8	120226070	6	131296647	16	165046320	29
16	020109086	26	052109076	23	120316210	8	131296648	16		30
21	020109087	4	052300600	31	120336030	8	131296649	16	185086291	20
22	020300008	12	052300700	43	120346241	8	131296678	16		21
30	023100006	9	064100045	2	120366152	8	131406360	15	185206082	38
35		11	064200010	6	120366162	8		16	185246060	39
36		14	064200012	8	120406050	6	131416170	17	185336252	30
43		27	064200015	2	120406070	6	131426200	15	185366060	36
10006370		33	064200020	6	120456222	8	131426230	17	185376140	36
0180070	023100008	8	064200025	2	120736081	9	131437300	14	185416300	30
010100625		14		6	120996060	42	131437301	14	185426130	30
010100630		11	064200030	6	125046150	11	131426310	14	185436120	30
010101030	023109002	14	064200040	2	125116140	11	131437303	14	185446140	30
010101035	024500008	24	064500010	32	125156170	11	131437360	17	185446157	30
010109119	025100008	14	064500030	27	125156180	12	131446006	17	185446158	30
010109235	025100010	14	067100022	27	125176080	11	131446074	17	185446162	30
010109264	025100012	23	068109036	24	125256120	9	131446075	17	185446165	30
010109270	025100016	38	080109061	29	125406080	11	131446076	17	185446182	30
010109341	026100010	20	110136251	6	125416020	11	131446077	17	185446187	30
010111055	026100024	26	110156141	3	125976120	11	131507100	14	185446188	30
010401212	026200008	12	110156151	3	130506140	34	131507110	14	185446216	30
010700865		29	110156161	2		35	131507120	14	185446246	30
011300612	026200010	11	110186050	2	130516069	35	131606290	15	185446251	30
	027100004	36	110366350	18	130516080	35	135596650	32	185606170	36
	027100006	32	110666050	24	130516081	35	135597040	32	185726340	29
011300616	027100010	20	110666090	24	130516082	35	135616600	33	185816120	21
		29	110706880	23	130516083	35	135996451	32	185846317	21
011300625	027109010	14	110756140	23	130516084	35	135996590	33		22
011300635	030300414	9	110996560	23	130516085	35	135996680	32	185846319	21
		32	111026490	24	130516086	35	140036120	13	185846320	21
011300645	030300816	4	111086050	6	130516087	35	140116140	13	185846321	21
	030309005	2	111086060	6	130516088	35	140166140	13	185846322	21
011300660	030500612	2	111136360	6	130516089	35	140186020	13	185846324	21
		3	111136370	6	130516090	35	140406310	23	185846325	21
011300680	030500616	2	111146991	6	130516091	35	140516130	25	185846327	21
011300816	030501025	2	115016710	4	130516092	35	140546020	25	185846328	21
	030509020	4	115016714	4	130996070	34	140606691	25	185846329	21
011300820	031100004	11	115016717	4	131017360	14	140986530	23	185846330	21
	034100508	9	115016790	4		16	140986581	24	185846357	21
011300860		26	115016794	4	131046120	14	145016870	27	185846360	21
	036500025	5	115016797	4	131116380	16	145146300	27	185846361	21
	036800005	11	115026211	4	131136350	14	145206021	27	185846362	22
011310612	036800006	12	115107290	5	131146070	16	145216151	27	185846363	21
	036800008	11	115107293	5	131156150	16	145306491	28	185846364	21
011310614	036800010	13	115107295	5	131176320	16	145336620	27	185846406	21
011310625	040106203	2	115176140	4	131176450	16	145386520	28	185846467	21
011310816	040136004	43	115236030	4	131186110	16	145536050	27	185866130	21
011310825	040156304	9	115276200	4	131196060	16	145996360	27	185866180	21
011311070	042309013	2	115326030	5	131226130	16	145996370	27	185976200	29
012100635	052100030	11	115376130	19	131226180	35	145996450	27	195816200	37
012100645	052100050	12	115396820	26	131246010	16	145996590	27	195906640	44
012100660	052100070	11	120016050	9	131246170	16	165026120	13	198216700	6
012100820	052100100	23	120026190	9	131256110	16	165106092	9	198216720	13
012109177		43	120076070	42	131296255	16	165166221	9	198216731	11

NUMERICAL INDEX

198216760	12
198216780	8
198216790	27
198216821	13
198217110	11
198236030	14
198416320	23
198436010	24
198436150	8
198466010	2
198466020	2
198466030	2
198486780	25
198486840	34
198517060	4
198517090	2
198517190	2
198517194	2
198517197	2
198586040	4
198586044	4
198586047	4
198586070	4
198586074	4
198586077	4
198636160	9
198636170	18
198736120	41
198996060	24
	25
199106020	14
199216230	9
199236540	13
199266180	13
199266190	4
199286150	13
199286160	13
199286170	13
199286180	13
199376230	42
199486220	8
199566651	42
114120070	43
114990013	43
13855125	17
13856109	17
140460130	43
160700031	43
160710011	43
160720020	43
160740010	43
160740070	43
160740080	43
185620200	43
185620220	43
185620230	43
185620270	43
185620290	43
185720230	40